

WHGC933E16X

gorenje
Life Simplified

Freestanding wall decorative cooker hood



Polyurethane filter



Noise level



TouchFree coating



SmartCurve



LedLight

Re-circulating hoods

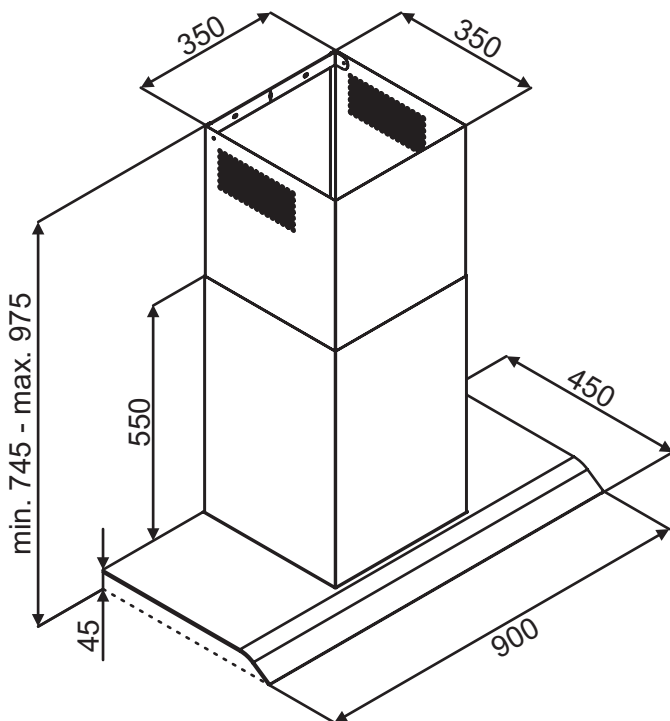

Wall mounted cooker hood

Venting with air extraction or recirculation

Energy class: **C**

Material of housing/chimney: **stainless steel and glass / stainless steel**

Colour of housing/chimney: **glass and stainless steel / stainless steel**

Lightning efficiency class: **A**

Grease filtering efficiency class: **C**

Fluid dynamic efficiency class: **C**

Maximum extraction rate by extraction operation: **462 m³/h**

Maximum extraction rate by recirculation operation: **392 m³/h**

Venting tube diameter: **15 cm**

Air flow by extraction version, step 1: **195 m³/h**

Air flow by extraction version, step 2: **331 m³/h**

Air flow by extraction version, step 3: **462 m³/h**

Electronic control

Control setting: **Button control**

Number of speed positions: **3**

TouchFree Inox

SmartCurve

Lamp type: **LED**

On/off light switch

Number of lights: **2**

Power of lights: **6 W**

Filter material: **Washable aluminium with polyurethane foam**

Coal filter code (optional as separate purchase): **530411**

Recirculation set number: **592278**

Motor type: **Capacitor motor**

Number of motors: **1**

No return airflow flap: **150 mm**

Max. noise level: **59 dB(A)re 1 pW**

Height: **550 mm**

Annual energy consumption: **55.1 kWh**

Dimensions (W×H×D): **90 × 55 × 45 cm**

Dimensions of packed product (W×H×D): **99 × 67.5 × 51.5 cm**

Net weight: **16.9 kg**

Gross weight: **21.8 kg**

Connected load: **141 W**

Nominal current of fuse: **10 amp**

Product code: **560155**

EAN code: **3838942121814**



<https://eg.gorenje.com/en/product/560155>