

Instructions for the use - Installation advices

CE (GB) BUILT-IN GAS OVENS

100% ELBA QUALITY
MADE IN ITALY



ELBA
TALENT FOR COOKING



Made in Italy

Dear Customer,

Thank you for having purchased and given your preference to our product.

The safety precautions and recommendations reported below are for your own safety and that of others. They will also provide a means by which to make full use of the features offered by your appliance.

Please preserve this booklet carefully. It may be useful in future, either to yourself or to others in the event that doubts should arise relating to its operation.

This appliance must be used only for the task it has explicitly been designed for, that is for cooking foodstuffs. Any other form of usage is to be considered as inappropriate and therefore dangerous.

The manufacturer declines all responsibility in the event of damage caused by improper, incorrect or illogical use of the appliance.

Before operating this oven, please read these instructions carefully.

CAUTION: this apparatus must only be installed in a permanently ventilated room in compliance with the applicable regulations.

DECLARATION OF CE CONFORMITY

This oven has been designed to be used only for cooking.

Any other use (such as heating a room) is improper and dangerous.

This oven has been designed, constructed, and marketed in compliance with:

- safety requirements of EU Directive “Gas” 2009/142/EC;
- safety requirements of EU Directive “Low voltage” 2006/95/EC;
- safety requirements of EU Directive “EMC” 2004/108/EC;
- requirements of EU Directive 93/68/EEC;
- requirements of EU Directive 2011/65/EU.



Important:

This appliance is designed and manufactured solely for the cooking of domestic (household) food and is not suitable for any non domestic application and therefore should not be used in a commercial environment.

This appliance guarantee will be void if the appliance is used within a non domestic environment i.e. a semi commercial, commercial or communal environment.

- Read the instructions carefully before installing and using the appliance.
- After unpacking the appliance, check that it is not damaged. In case of doubt, do not use the appliance and contact your supplier or a qualified engineer.
- Remove all the packing materials (i.e. plastic bags, polystyrene foam, etc.) and do not leave it around within easy reach of children, as these may cause serious injuries. The packaging materials are recyclable (symbol ).
- The installation and all the gas/electrical connections shall be made by a qualified engineer in compliance with local regulations in force and following the manufacturer's instructions.
- Do not attempt to modify the technical characteristics of the appliance, as it may become dangerous to use.

USING THE OVEN FOR THE FIRST TIME

You are advised to carry out the following operations:

- Assemble the interior of the oven as described under the heading "Cleaning and maintenance".
- Switch the empty oven ON at maximum temperature for about two hours to eliminate traces of grease and smell from the components.
- Let the oven cool down, switch off the electrical supply, then clean the inside of the oven with a cloth soaked in water and neutral detergent and dry thoroughly.

IMPORTANT PRECAUTIONS AND RECOMMENDATIONS FOR USE OF ELECTRICAL APPLIANCES

Use of any electrical appliance implies the necessity to follow a series of fundamental rules. In particular:

- never touch the appliance with wet hands or feet;
- do not operate the appliance barefooted;
- do not allow children or disabled people to use the appliance without your supervision.

The manufacturer cannot be held responsible for any damages caused by improper, incorrect or unreasonable use of the appliance.

IMPORTANT SAFEGUARDS & RECOMMENDATIONS

- If you should decide not to use this appliance any longer (or decide to substitute an older model), before disposing of it, it is recommended that it is made inoperative in an appropriate manner in accordance to health and environmental protection regulations, ensuring in particular that all potentially hazardous parts be made harmless, especially in relation to children who could play with unused appliances.
- Some appliances are supplied with a protective film on steel and aluminium parts. This film must be removed before using the appliance.
- Do not carry out any cleaning or maintenance without first disconnecting the appliance from the electrical supply.
- During and after use of the oven, certain parts will become very hot. Do not touch hot parts.
- After use always ensure that the control knobs are in the OFF position (“●”, “O” or “0”).
- Keep children away from the oven during use.
- Household appliances are not intended to be played with by children.
- Children, or persons with a disability which limits their ability to use the appliance, should have a responsible person to instruct them in its use. The instructor should be satisfied that they can use the appliance without danger to themselves or their surroundings.
- **WARNING.** When correctly installed, your product meets all safety requirements laid down for this type of product category. However special care should be taken around the rear or the underneath of the appliance as these areas are not designed or intended to be touched and may contain sharp or rough edges, that may cause injury.
- Fire Risk! Do not store inflammable materials inside the oven.
- Always use oven gloves when removing the shelves and food trays from the oven whilst hot.
- Clean the oven regularly and do not allow fat or oils to build up in the oven base or trays. Remove spillages as soon as they occur.
- Do not line the oven walls with aluminium foil. Do not place baking trays or the drip tray on the base of the oven chamber.
- Always stand back from the oven when opening the oven door to allow steam and hot air to escape before removing the food.
- Do not hang towels, dishcloths or other items on the oven or its handle – as this could be a fire hazard.
- Make sure that electrical cords connecting other appliances in the proximity cannot become entrapped in the oven door.
- Important: This appliance has been designed for domestic use only.
- Safe food handling: leave food in the oven for as short a time as possible before and after cooking. This is to avoid contamination by organisms which may cause food poisoning. Take particular care during warmer weather.

1 CONTROL PANELS

Fig. 1.1

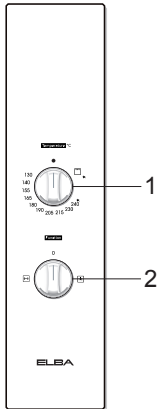

Fig. 1.2

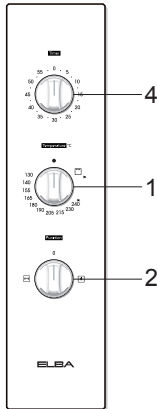

Fig. 1.3

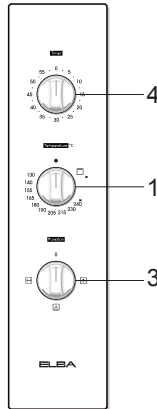

Fig. 1.4

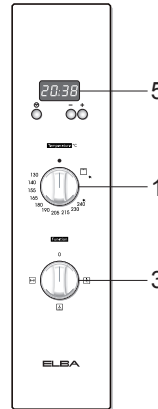
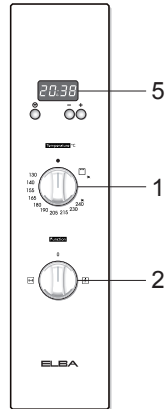

Fig. 1.5



NOTES: The knobs and symbols may vary.
The symbols may be printed on the knob itself.

CONTROLS DESCRIPTION

1. Gas oven/grill thermostat control knob
2. Oven light / rotisserie control knob
3. Oven light / rotisserie / fan motor control knob
4. 60' or 120' alarm knob
5. Electronic clock with alarm

Notes:

- If the product is a “fan assisted” gas oven, the oven light/roast control knob has also the position  (fan motor) - models in figs 1.3 and 1.4.
- The electric ignition is incorporated in the thermostat control knob.
- The appliance has a safety valve system fitted, the flow of gas will be stopped if and when the flame should accidentally go out.

CAUTION:

If the burner is accidentally extinguished, turn the gas off at the control knob and wait at least 1 minute before attempting to relight.

CAUTION:

Gas appliances produce heat and humidity in the environment in which they are installed. Ensure that the cooking area is well ventilated by opening the natural ventilation grilles or by installing an extractor hood connected to an outlet duct.

CAUTION:

If the appliance is used for a prolonged time it may be necessary to provide further ventilation by opening a window or by increasing the suction power of the extractor hood (if fitted).

2

HOW TO USE THE OVEN

ATTENTION:

Attention: the oven door becomes very hot during operation and very hot steam goes out from the louvers in the top area. Keep children away.

The door is hot, use the handle.

During use the appliance becomes hot. Care should be taken to avoid touching the heating elements inside the oven.

TECHNICAL FEATURES

The oven is furnished completely clean. It is advisable however, upon first use, to turn the oven on to the maximum temperature to eliminate possible traces of grease from the oven burner.

The same operation shall be done with the gas grill.

This oven is fitted with:

- One gas oven burner (4,00 kW), located at the bottom, providing self-ignition and safety device.
- One gas grill burner (2,50 kW), placed on the top, providing self-ignition and safety device.
- **Only for the “fan assisted” models (models in fig. 1.3 and 1.4)** - A fan motor, positioned on the rear panel, which can be used only in combination with the oven burner.

IMPORTANT NOTE - It is not possible to use the fan motor in combination with the gas grill: a safety device switches off the fan motor when the gas oven/grill control knob is turned on grill position.

OPERATING PRINCIPLES

Heating and cooking in the gas oven are obtained in the following ways:

a. by normal convection

The heat is produced by the oven gas burner.

b. by forced convection (only for the “fan assisted” models - models in fig. 1.3 and 1.4)

The heat produced by the oven burner is distributed throughout the oven by the fan.

c. by radiation

The heat is radiated by the gas grill.

COOLING FAN MOTOR

This appliance incorporates a safety cooling fan motor to achieve optimum efficiency of the controls, ensure lower surface temperatures are maintained and cool the internal components.

Oven burner operating: the cooling fan motor turns on automatically when igniting the burner.

It may run on (for various minutes) even after the oven burner has been turned off.

Grill burner operating: the cooling fan motor turns on automatically at a fixed temperature (not when igniting the burner). It may run on (for various minutes) even after the grill burner has been turned off.

IMPORTANT NOTES:

- **Do not use the appliance in case of power failure or if the cooling fan motor is damaged. The appliance may overheat and get damaged due to the non-operation of the cooling fan motor.**
- **In case of failure of the cooling fan motor during the operation of the gas grill, the grill burner is turned off automatically after about 20 minutes. In that case do not use the oven or the grill and contact the after-sales service.**
- **When the cooling fan motor is operating correctly there is an air flow in the top area of the appliance.**

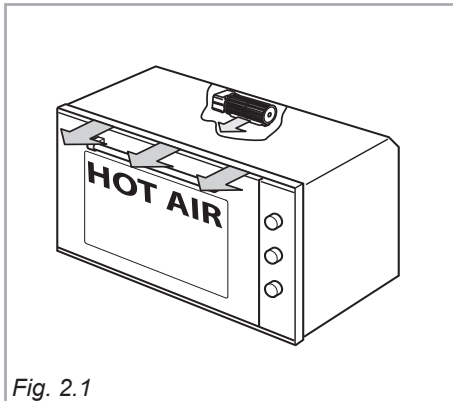

Fig. 2.1

OVEN BURNER

The gas flow to the burner is regulated by a thermostat which allow to maintain the oven temperature constant.

The control of the temperature is assured by a thermostatic probe positioned inside the oven.

The probe must be always kept in its housing, in a clean condition, as an incorrect position or encrustment may cause an alteration in the control of the temperature.

Moreover, the thermostat is fitted with a safety valve which automatically shuts off the gas supply when the flame goes out.

THERMOSTAT

The numbers printed on the control panel or on the knob (fig. 2.2) indicate the increasing oven temperature value (see table below).

To regulate the temperature, set the knob to the chosen number. The “FAN ASSISTED GAS OVEN” column refers to the oven burner used in combination with the fan motor (forced convection cooking: only for the “fan assisted” models - models in figs. 1.3 and 1.4), while the “GAS OVEN” column refers to the oven burner used in the normal convection mode (without fan motor). The ★ symbol close to the maximum position indicates that the electric ignition is incorporated into the knob (activated by the knob itself).

NOTES: The knob and symbols may vary. The symbols may be printed on the knob itself.

Temperature °C

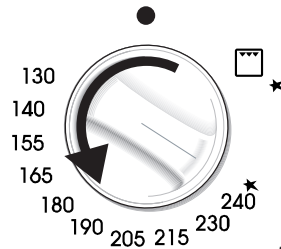

Fig. 2.2

THERMOSTAT GRADE TABLE (°C)

Knob position	GAS OVEN	FAN ASSISTED GAS OVEN
130 (or 1)	130	130
140 (or 2)	140	140
155 (or 3)	155	155
165 (or 4)	165	165
180 (or 5)	180	180
190 (or 6)	190	190
205 (or 7)	205	205
215 (or 8)	215	215
230 (or 9)	230	230
240 (or 10)	240	240

IGNITION OF THE OVEN BURNER

IMPORTANT: The oven door must be open during this operation.

To ignite the oven burner:

- 1 – Open the oven door to the full extent.

WARNING: Risk of explosion! The oven door must be open during this operation.

- 2 – Lightly press and turn the thermostat knob anti-clockwise to the maximum position ★ (fig. 2.2). Press the knob firmly until the burner lights.

Never continue this operation for more than 15 seconds. If the burner has still not ignited, wait for about 1 minute prior to repeating the ignition.

In case of mains failure, approach a lighted match or taper to the opening “A” (fig. 2.3) and immediately press the knob firmly.

- 3 – Wait about 10/15 seconds after the burner lighting before releasing the knob (time of priming of the valve).
- 4 – Close the oven door slowly and adjust the burner according to the power required.

If the flame extinguishes for any reason, the safety valve will automatically shut off the gas supply to the burner.

To re-light the burner, first turn the thermostat control knob to position “●” or “O” (off), wait for at least 1 minute and then repeat the lighting procedure.

For the correct use of the gas oven see the chapters “COOKING WITH GAS OVEN” and “COOKING WITH FAN ASSISTED GAS OVEN” (only for the “fan assisted” models - models in fig. 1.3 and 1.4).

During and after use of the oven, certain parts will become very hot. Keep children away.

For a correct pre-heating, we suggest to remove tray and shelf from the oven and introduce them again after 15 minutes.

ATTENTION: In case of manual lighting, never turn the thermostat before approaching a flame to the hole “A” of the floor.

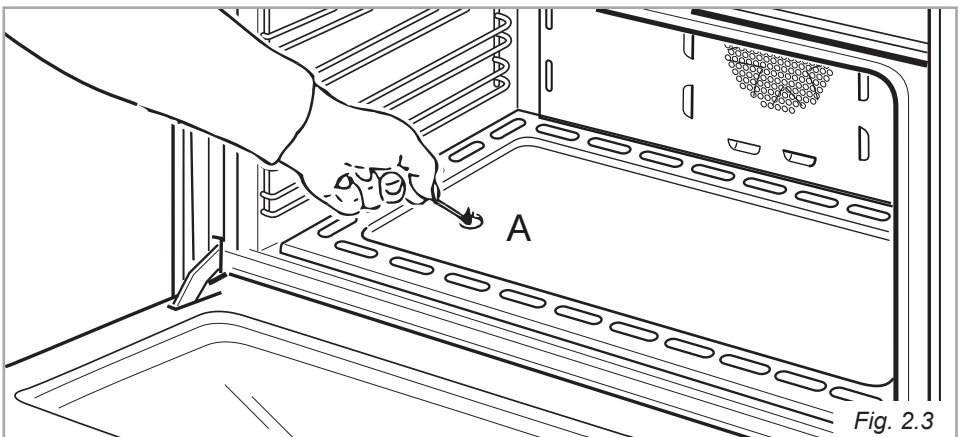

Fig. 2.3

IGNITION OF THE GRILL BURNER

IMPORTANT: The oven door must be open during this operation.

To ignite the grill burner:

- 1 – Open the oven door to the full extent.

WARNING: Risk of explosion! The oven door must be open during this operation.

- 2 – Lightly press and turn the thermostat knob clockwise to the position  (fig. 2.4), Press the knob firmly until the burner lights.

Never continue this operation for more than 15 seconds. If the burner has still not ignited, wait for about 1 minute prior to repeating the ignition.

In case of mains failure, approach a lighted match or taper to the pipe of the burner (fig. 2.5) and immediately press the knob firmly.

- 3 – Wait about 10/15 seconds after the burner lighting before releasing the knob (time of priming of the valve).

If the flame extinguishes for any reason, the safety valve will automatically shut off the gas supply to the burner.

To re-light the burner, first turn the thermostat control knob to position “●” or “O” (off), wait for at least 1 minute and then repeat the lighting procedure.

For the correct use of the gas grill see specific instructions in the section ‘USE OF THE GRILL’.

IMPORTANT NOTE (Only for the “fan assisted” models - models in fig. 1.3 and 1.4): It is not possible to use the fan motor in combination with the gas grill; a safety device switches off the fan motor when the gas oven/grill control knob is turned on grill position.

ATTENTION: the oven door becomes very hot during operation. Keep children away.

During and after use of the grill, certain parts will become very hot. Keep children away.

ATTENTION: In case of manual lighting, never turn the thermostat before approaching a flame to the burner.

NOTES: The knob and symbols may vary. The symbols may be printed on the knob itself.

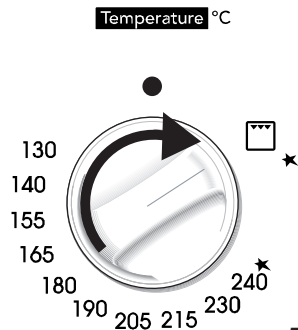

Fig. 2.4

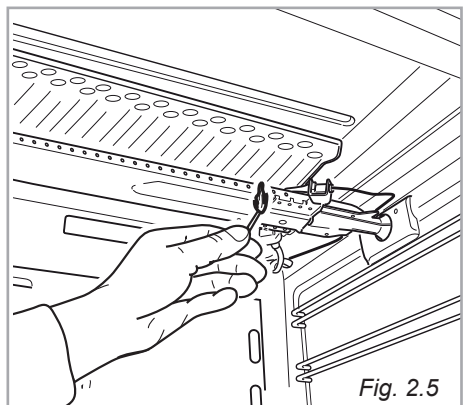

Fig. 2.5

COOKING WITH GAS OVEN

Before introducing the food, preheat the oven to the desired temperature.

For a correct preheating operation, it is advisable to remove the tray from the oven and introduce it together with the food, when the oven has reached the desired temperature.

Check the cooking time and turn off the oven 5 minutes before the theoretical time to recuperate the stored heat.

FAN MOTOR

(Only for the “fan assisted” models - models in fig. 1.3 and 1.4)

The fan motor is designed to distribute throughout the oven the heat generated by the oven gas burner.

The fan is controlled by a knob (fig. 2.6).

- To operate the fan motor turn the knob indicated in fig. 2.6 to  position.
IMPORTANT : The fan motor operates only if the oven burner has been ignited.
- To switch it off turn the knob to the off position (“O” or “0”).

IMPORTANT: Switch on the fan only after the ignition of the gas burner.

COOKING WITH FAN ASSISTED GAS OVEN

(Only for the “fan assisted” models - models in fig. 1.3 and 1.4)

OVEN BURNER AND FAN MOTOR

After the ignition of the gas burner, close the oven door and switch on the fan motor. Before introducing the food, preheat the oven to the desired temperature.

For a correct preheating operation, it is advisable to remove the tray from the oven and introduce it together with the food, when the oven has reached the desired temperature.

Check the cooking time and turn off the oven 5 minutes before the theoretical time to recuperate the stored heat.

Only for the “fan assisted” models - models in fig. 1.3 and 1.4

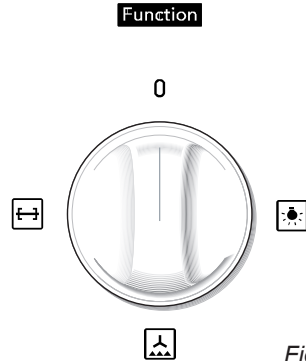

Fig. 2.6

NOTES: The knob and symbols may vary. The symbols may be printed on the knob itself.

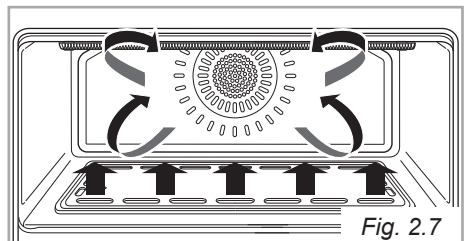

Fig. 2.7

USE OF THE GRILL

Very important: the grill must always be used with the oven door closed.

Turn on the grill, as explained in the preceding paragraphs and let the oven preheat for about 5 minutes with the door closed.

Introduce the food to be cooked, positioning the rack as close to the grill as possible.

The dripping pan should be placed under the rack to catch the cooking juices and fats.

Note: It is recommended that you do not grill for longer than 30 minutes at any one time.

Attention: the oven door becomes very hot during operation. Keep children away.

NOTES: The knob and symbols may vary. The symbols may be printed on the knob itself.

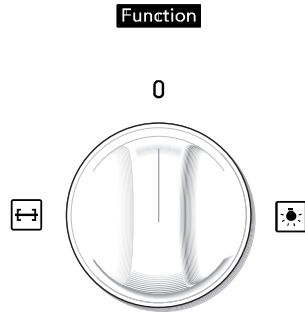



Fig. 2.8

OVEN LIGHT

The oven is fitted with an interior lamp to allow the visual inspection during the cooking.

To light the oven lamp turn the knob indicated in fig. 2.6 or 2.8 to the  position

ROTISSERIE

The oven is fitted with a rotisserie.

To operate the rotisserie motor turn the knob indicated in fig. 2.6 or 2.8 to  position.

For the correct use see specific instructions in the section 'USING THE ROTISSERIE'.

OVEN DOOR GUARD

The glass on the oven door reaches high temperatures during the use of the gas oven.

In the presence of children, to avoid contact with the hot surfaces of the door, you should replace the oven door with a another one fitted with three panes of glass (low thermal conductivity).

This door is supplied as an accessory at extra cost, if required. Contact the After-Sales Service and indicate the model name of your product.

USING THE ROTISSERIE (Models with rod support as per figures here below)

Very important: the rotisserie must always be used with the oven door closed.

- Insert the tray "L" into the lowest rack holders of the oven and insert the rod support "T" into the intermediate rack holders (figs. 2.9a - 2.9b).
- Put the meat to be cooked onto the rod, being careful to secure it in the center with the special forks (fig. 2.11).
- Remove the grip "H" by turning it to the left (fig. 2.11).
- Insert completely the rotisserie support; the shaft "S" must be inserted (through the hole cover) in the spit motor collar "G" (figs. 2.10a - 2.10b).

The rotation direction of the rotisserie can be either clockwise or counterclockwise.

IMPORTANT NOTE (ONLY FOR MODELS WITH TELESCOPIC SLIDING SHELF SUPPORTS SUPPLIED - SEE PAGE 20)
When cooking with the rotisserie DO NOT position the rotisserie support "T" on the sliding shelf supports (if fitted).

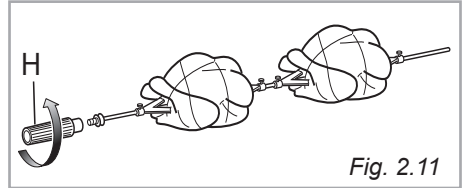

MODELS WITH EMBOSSED CAVITY

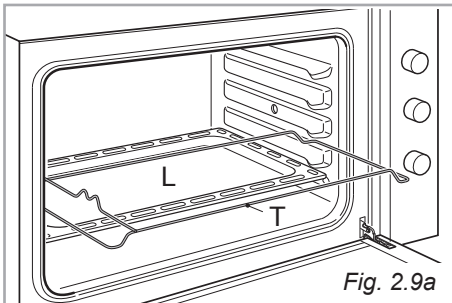

MODELS WITH WIRE RACKS

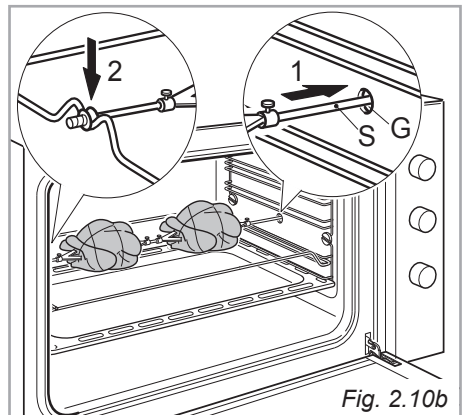
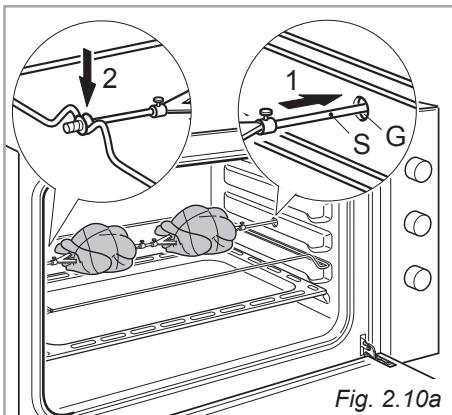
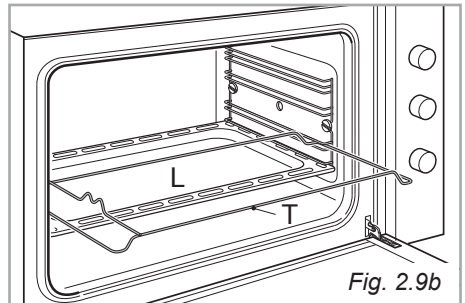

USING THE ROTISSERIE (Models with rod support as per figures here below)

Very important: the rotisserie must always be used with the oven door closed.

1. Prepare the rotisserie support (fig. 2.12).

- Place the grill tray on the benchtop.
- Insert the supports into the lock studs.
- Push the supports all the way down to lock them in firmly.

2. Secure the meat (fig. 2.13).

Important!

Take care, the forks are sharp!

When securing the meat, ensure that:

- The skewer goes through the centre of the meat.
- The forks hold the meat firmly in place.
- The fork screws are tightened.
- There are no loose or projecting parts. Poultry should be trussed.

Note: the rotisserie can rotate up to 6 kg of meat.

3. Position the skewer on the support (fig. 2.14).

- Place the skewer on the support, and check that the meat does not touch the grill tray.
- Twist the handle off. It must not be left in the oven.

4. Place the rotisserie in the oven (fig. 2.15).

- Slide the grill tray all the way to the back on the lower shelf position.

IMPORTANT NOTE (ONLY FOR MODELS WITH TELESCOPIC SLIDING SHELF SUPPORTS SUPPLIED - SEE PAGE 20).

DO NOT place the grill tray on the sliding shelf supports (if fitted).

- Push the skewer through the hole cover on the right-hand wall of the oven, then insert it fully into the rotisserie drive hole.

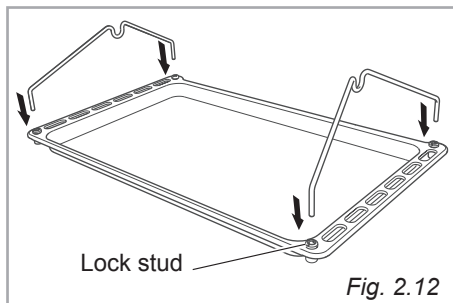

Fig. 2.12

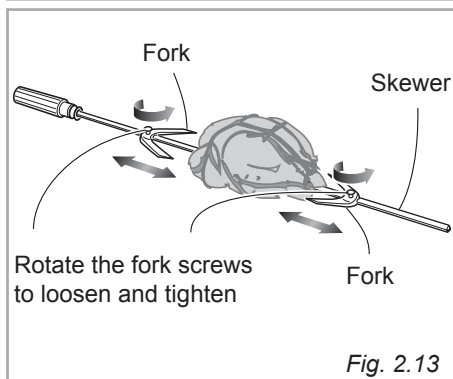

Fig. 2.13

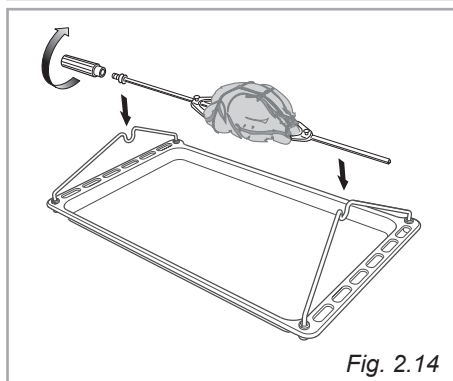

Fig. 2.14

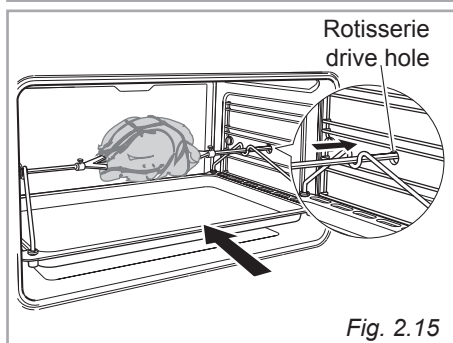

Fig. 2.15

3

ALARM OR ELECTRONIC CLOCK

60' ALARM (fig. 3.1)

The minute counter is a timed acoustic warning device which can be set for a maximum of 60 minutes.

The knob must be rotated clockwise as far as the 60 minute position and then set to the required time by rotating it anticlockwise.

IMPORTANT WARNING: This is only a mechanical timer.

Remember to turn off the oven/grill manually.

120' ALARM (fig. 3.2)

The minute counter is a timed acoustic warning device which can be set for a maximum of 120 minutes.

The knob must be rotated clockwise as far as the 120 minute position and then set to the required time by rotating it anticlockwise.

IMPORTANT WARNING: This is only a mechanical timer.

Remember to turn off the oven/grill manually.

**NOTES: The knob and symbols may vary.
The symbols may be printed on the knob itself.**

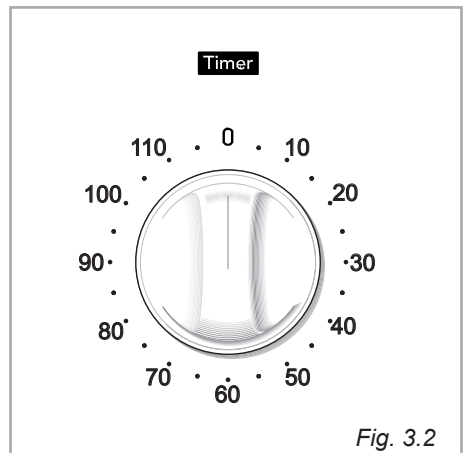
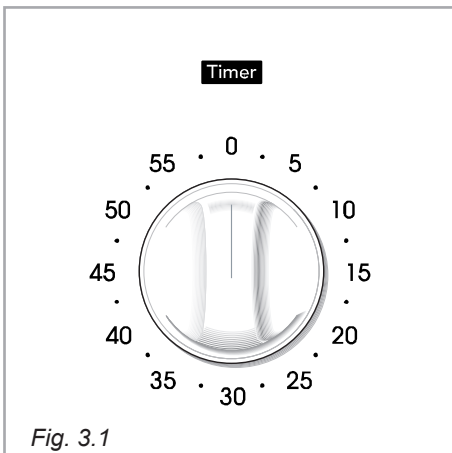





ELECTRONIC CLOCK WITH ALARM

(fig. 3.3)

The electronic clock is a device which groups the following functions:

- 24 hours clock with illuminated display
- 99 minutes alarm.





Upon immediate connection of the oven or after a blackout, three zeros will flash on the display.



To set the hour it is necessary to push the  button and then, within 7 seconds, the  () or  () button until you have set the exact hour.







An energy black-out makes the clock go to zero.

ELECTRONIC ALARM



The alarm program consists only of a buzzer which may be set for a maximum period of 99 minutes.

To set the time, push the  () or  () button until you obtain the desired time in the display. Having finished the setting, the  symbol will be lighted and the countdown will start immediately.

At the end of the time, an intermittent buzzer, during 7 minutes, will go off; this can be stopped by pressing the  () button.

To stop the alarm countdown in any moment press the  () and  () buttons together and release the  () button first.

SETTING THE FREQUENCY OF THE ALARM SOUND

The selection from 3 possibilities of sound can be made by pressing the  () button.

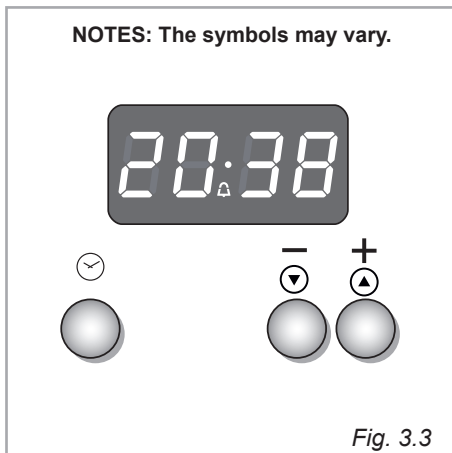

IMPORTANT WARNING: This is only a mechanical timer.

Remember to turn off the oven/grill manually.

4

CLEANING AND MAINTENANCE

GENERAL ADVICE

Important:

Before any operation of cleaning and maintenance disconnect the appliance from the electrical supply.

- It is advisable to clean when the appliance is cold and especially for cleaning the enamelled parts.
- Avoid leaving alkaline or acidic substances (lemon juice, vinegar, etc.) on the surfaces.
- Avoid using cleaning products with a chlorine or acidic base.
- The oven must always be cleaned after every use, using suitable products.

WARNING

When correctly installed, your product meets all safety requirements laid down for this type of product category. However special care should be taken around the rear or the underneath of the appliance as these areas are not designed or intended to be touched and may contain sharp or rough edges, that may cause injury.

INSIDE OF OVEN

The oven should always be cleaned after use when it has cooled down.

The cavity should be cleaned using a mild detergent solution and warm water.

Suitable proprietary chemical cleaners may be used after first consulting with the manufacturers recommendations and testing a small sample of the oven cavity.

Abrasive cleaning agents or scouring pads/cloths should not be used on the cavity surface.

NOTE: The manufacturers of this appliance will accept no responsibility for damage caused by chemical or abrasive cleaning.

Let the oven cool down and pay special attention no to touch the hot heating elements inside the oven cavity.

Do not use a steam cleaner because the moisture can get into the appliance thus make it unsafe.

Do not store flammable material in the oven.

ENAMELLED PARTS

All the enamelled parts must be cleaned with a sponge and soapy water only or other non-abrasive products.

Dry preferably with a microfibre or soft cloth.

STAINLESS STEEL SURFACES (MODELS WITHOUT ANTI-FINGERPRINT TREATMENT), ALUMINIUM PARTS AND PAINTED OR SILK-SCREEN PRINTED SURFACES

Clean using an appropriate product. Always dry thoroughly.

IMPORTANT: these parts must be cleaned very carefully to avoid scratching and abrasion.

You are advised to use a soft cloth and neutral soap.

STAINLESS STEEL SURFACES WITH ANTI-FINGERPRINT TREATMENT (SOME MODELS ONLY)

CAUTION

The stainless steel front surfaces used in some ovens are protected with a Special Lacquer to reduce finger-print marks.

To avoid damaging this lacquer, do not clean the stainless steel with abrasive cleaners or abrasive cloths or scouring pads.

ONLY SOAP/WARM WATER MUST BE USED TO CLEAN THE STAINLESS STEEL SURFACES.

GLASS CONTROL PANEL (MODELS WITH GLASS CONTROL PANEL)

Clean using an appropriate product.

Always dry thoroughly.

Do not use harsh abrasive cleaners or sharp metal scrapers to clean the control panel since they can scratch the surface, which may result in shattering of the glass.

Do not use harsh abrasive cleaners or sharp metal scrapers to clean the oven door glass since they can scratch the surface, which may result in shattering of the glass.

OVEN FITTING OUT

MODELS WITH EMBOSSED CAVITY

The oven shelf must be inserted operating as per figure 4.1a.

To pull it out operate in the inverse order.

Some model only: The oven shelf is provided with a security block to prevent accidental extraction. It must be inserted operating as per figure 4.1b.

To pull it out operate in the inverse order.

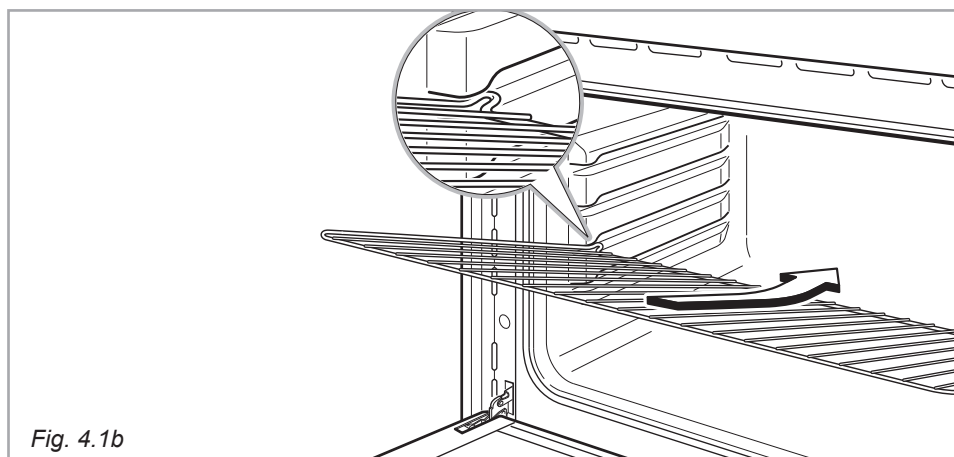
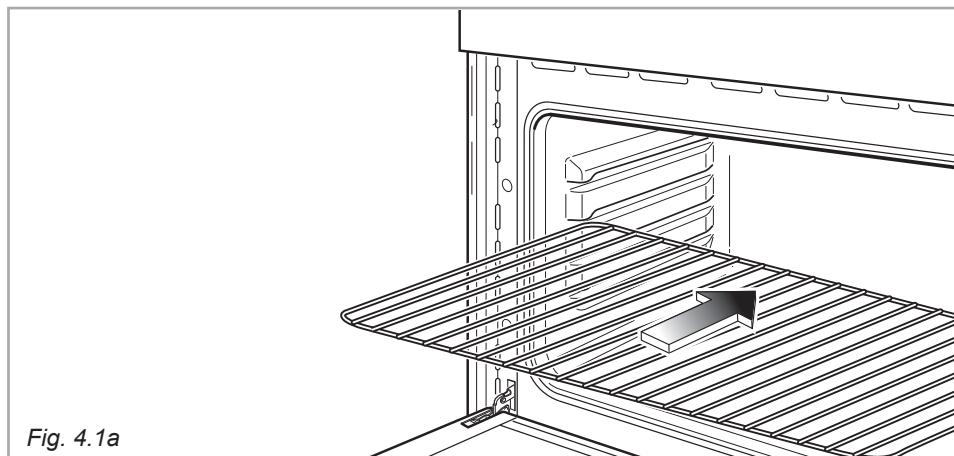

MODELS WITH WIRE RACKS

- Assemble the wire racks to the oven walls using the 2 screws (fig. 4.2).
In the models with catalytic panels supplied, interpose the catalytic panels “A” with the arrow up (fig. 4.2). The catalytic panel with the hole for the rotisserie must be positioned on the right oven wall. DO NOT INTERPOSE THE CATALYTIC PANEL WITHOUT THE HOLE ON THE RIGHT OVEN WALL.
- Slide in, on the guides, the shelf and the tray (fig. 4.3).
The shelf must be fitted so that the safety catch, which stops it sliding out, faces the inside of the oven.
- To dismantle, operate in reverse order.

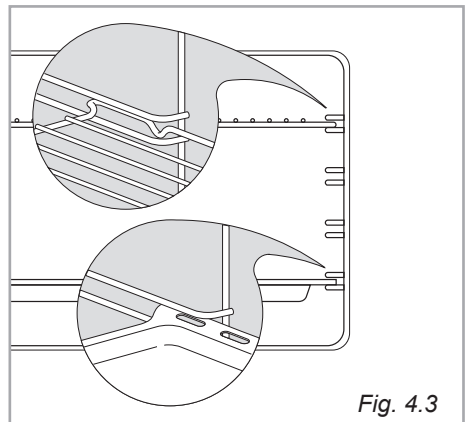

Fig. 4.3

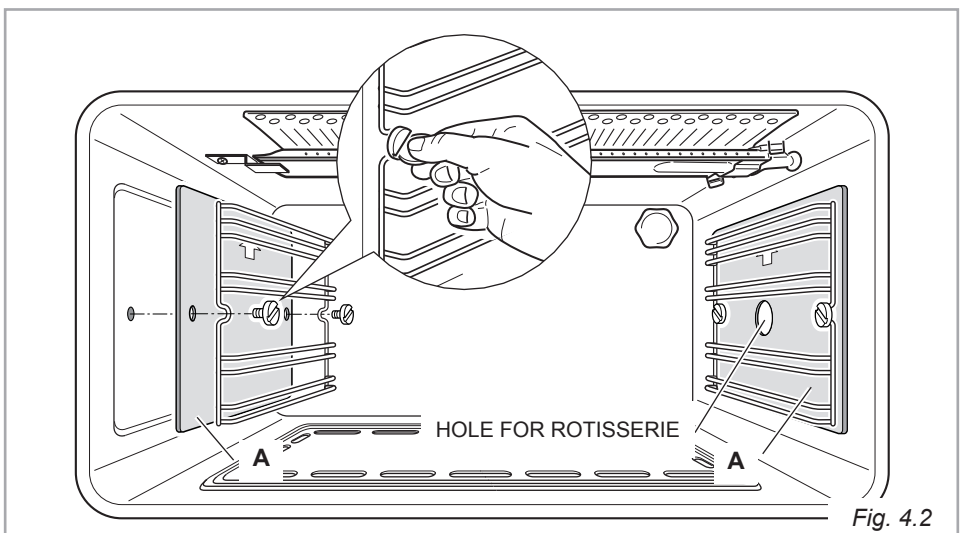

Fig. 4.2

TELESCOPIC SLIDING SHELF SUPPORTS (SUPPLIED WITH SOME MODELS ONLY)

The telescopic sliding shelf supports make it safer and easier to insert and remove the oven shelf and tray. They stop when they are pulled out to the maximum position.

Important! When fitting the sliding shelf supports, make sure that you fit:

- The slides to the top wire of a rack. They do not fit on the lower wire.
- The slides so that they run out towards the oven door.
- Both sides of each pair of shelf slides.
- Both sides on the same level.

TO FIX THE SLIDING SHELF SUPPORT ONTO THE SIDE RACKS:

- Screw the side racks onto the oven walls (and the catalytic liners if supplied - fig. 4.2).
- Fit the sliding shelf support onto the top wire of a rack and press (fig. 4.4). You will hear a click as the safety locks clip over the wire.

IMPORTANT NOTE: When cooking with the rotisserie **DO NOT** position the rotisserie support on the sliding shelf supports.

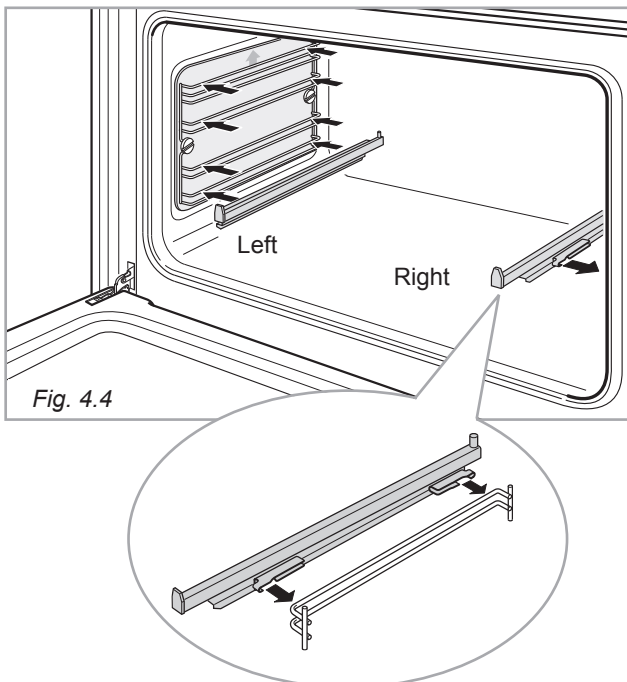

TO REMOVE THE TELESCOPIC SLIDING SHELF SUPPORTS:

- Remove the side racks (and the catalytic liners if supplied) by unscrewing the fixing screws (fig. 4.5).
- Lay down the telescopic sliding shelf support and side racks, with the telescopic sliding shelf support underneath.
- Find the safety locks. These are the tabs that clip over the wire of the side rack (arrow 1 in fig. 4.6).
- Pull the safety locks away from the wire to release the wire (arrow 2 in fig. 4.6).

CLEANING THE SLIDING SHELF SUPPORTS

- Wipe the supports with a damp cloth and a mild detergent only.
- Do not wash them in the dishwasher, immerse them in soapy water, or use oven cleaner on them.

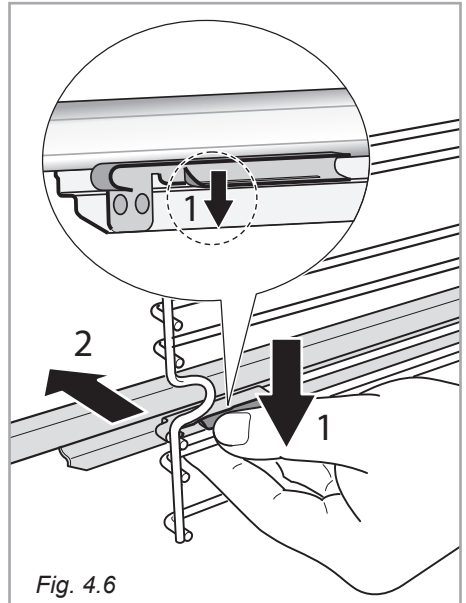
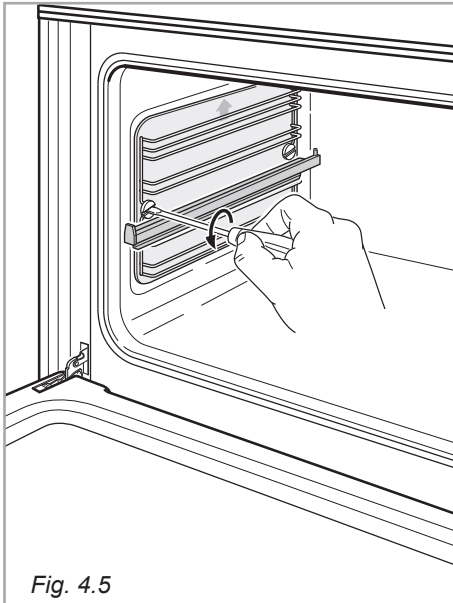

ADVICE FOR USE AND MAINTENANCE OF CATALYTIC PANELS (SOME MODELS ONLY)

The catalytic panels are covered with special microporous enamel which absorbs and does away with oil and fat splashes during normal baking over 200°C.

If, after cooking very fatty foods, the panels remain dirty, operate the oven “idling” on max temperature for about 30 minutes.

These panels do not require to be cleaned, however it is advised to periodically remove them from the oven (at least the side panels) and to wash them with tepid soapy water and then wipe off with a soft cloth.

DO NOT CLEAN OR WASH THEM WITH ABRASIVE PRODUCTS OR WITH PRODUCTS CONTAINING ACIDS OR ALKALIS.

The side panels are reversible and when the catalytic microporous enamel degrades, they can be turned to the other side.

GREASE FILTER - FAN ASSISTED OVENS (SOME MODELS ONLY)

- A special screen is provided at the back of the oven to catch grease particles, mainly when meat is being roasted (fig. 4.7).
- When baking pastry etc. this filter should be removed.
- Slide in the grease filter on the back of the oven as in fig. 4.7.
- **Clean the filter after any cooking!**
The grease filter can be removed for cleaning and should be washed regularly in hot soapy water.
Always clean the filter after cooking as any solid residues on it might adversely affect the oven performance.
- Always dry the filter properly before fitting it back into the oven.

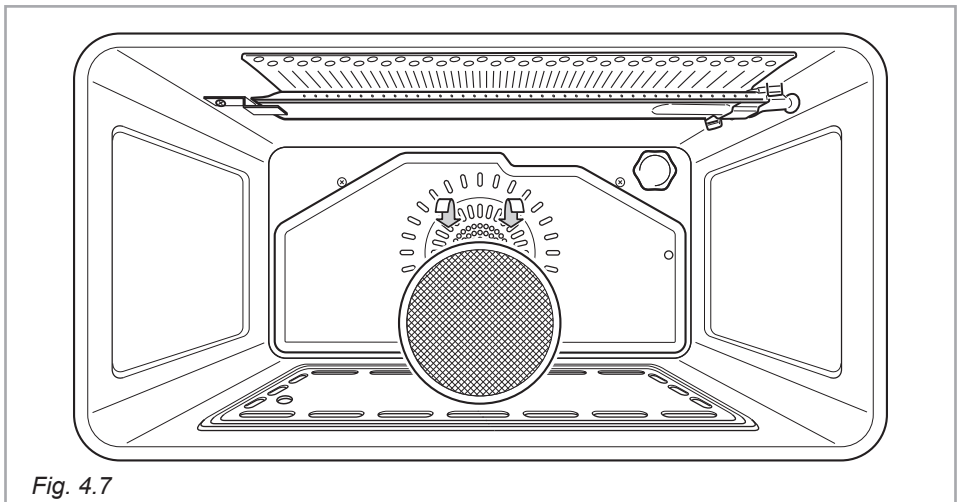

Fig. 4.7

REPLACING THE OVEN LAMP

WARNING: Ensure the appliance is switched off before replacing the lamp to avoid the possibility of electric shock.

- Let the oven cavity and the heating elements to cool down.
- Switch off the electrical supply.
- Remove the protective cover "A" (fig. 4.8a - 4.8b).
- Unscrew and replace the bulb "B" with a new one suitable for high temperatures (300°C) having the following specifications: 220-240V, E14 and same power (check watt power as stamped in the bulb itself) of the replaced bulb.
- Refit the protective cover "A".

Note: Oven bulb replacement is not covered by your guarantee.

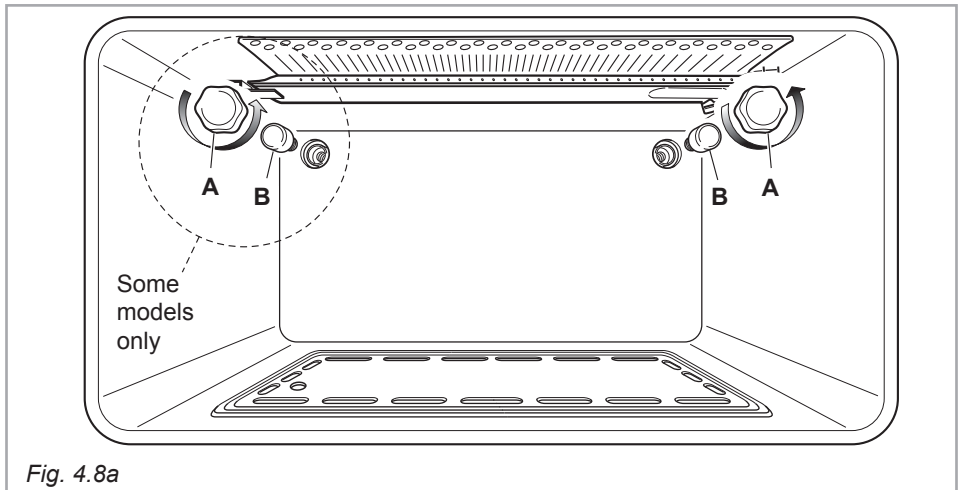

Fig. 4.8a

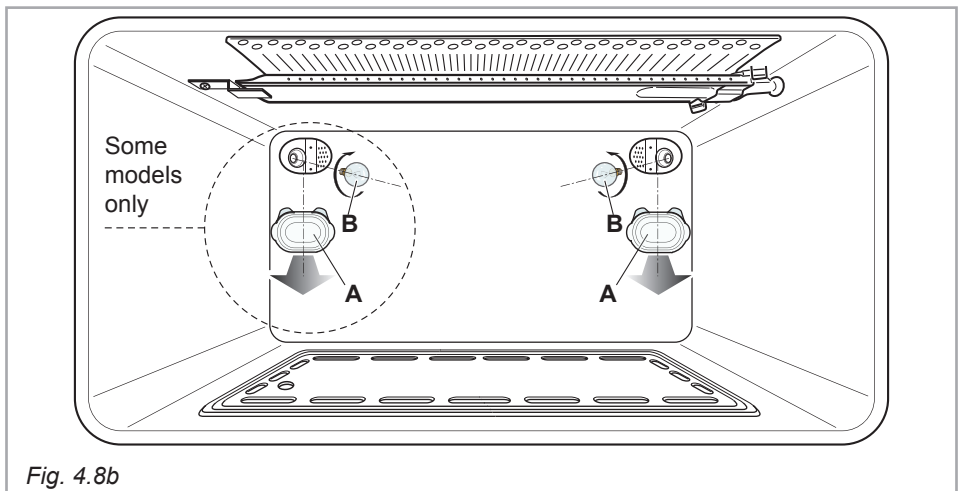

Fig. 4.8b

REMOVING THE OVEN DOOR

Take care, the oven door is heavy. If you have any doubts, do not attempt to remove the door.

The oven door can easily be removed as follows:

- Open the door to the full extent (fig. 4.9).
- Open the lever "A" completely on the left and right hinges (fig. 4.10).
- Hold the door as shown in fig. 4.12.
- Gently close the door (fig. 4.11) until left and right hinge levers "A" are hooked to part "B" of the door (fig. 4.10).
- Withdraw the hinge hooks from their location following arrow "C" (fig. 4.13).
- Rest the door on a soft surface.

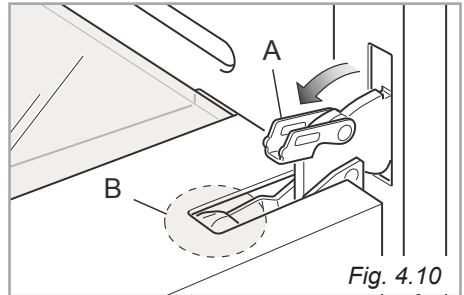
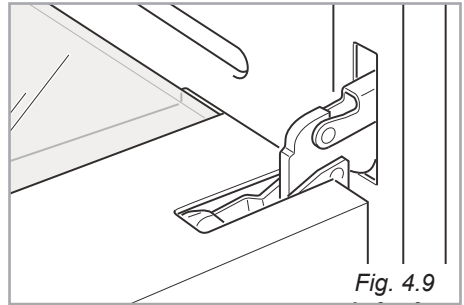

Important!

Always keep a safe distance from the door hinges, paying special attention to position of your hands.

If the door hinges are not correctly hooked, they could unhook and close suddenly and unexpectedly with risk of injury.

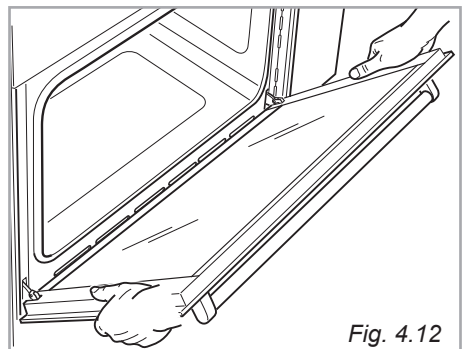
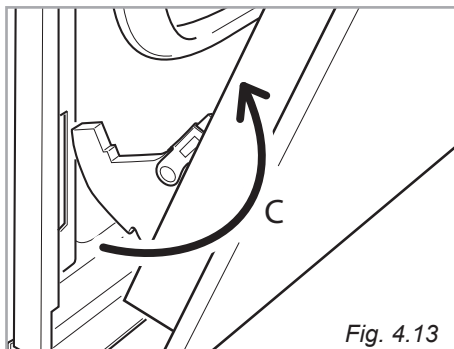
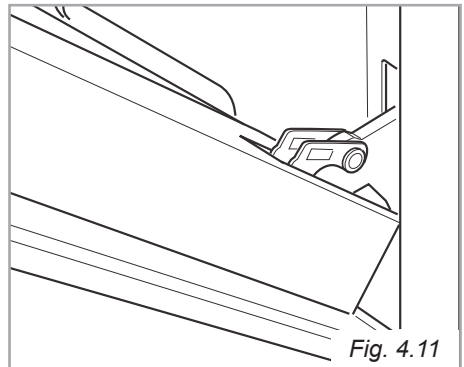
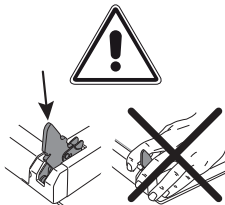

REFIT THE DOOR

- Hold the door firmly (fig. 4.14).
- Insert the hinge tongues into the slots, making sure that the groove drops into place as shown in the fig. 4.15.
- Open the door to its full extent.
- Fully close the levers “A” on the left and right hinges, as shown in the figure fig. 4.16.
- Close the door and check that it is properly in place.

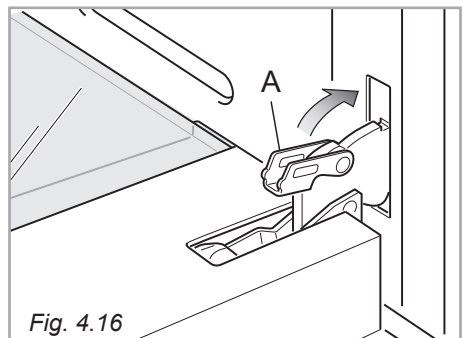
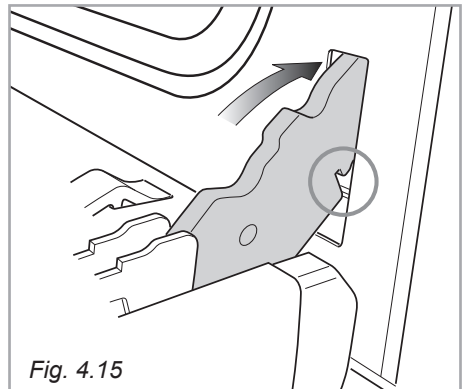
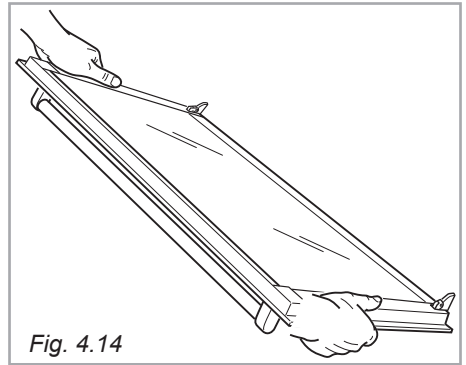

REMOVING AND REPLACING THE INNER DOOR GLASS PANE FOR CLEANING (only for the models with removable inner pane of glass)

If you wish to clean the inner glass of the door, make sure you follow the precautions and instructions very carefully.

Replacing the glass pane and the door incorrectly may result in damage to the oven and may void your warranty.

IMPORTANT!

- Take care, the oven door is heavy. If you have any doubts, do not attempt to remove the door.
- Make sure the oven and all its parts have cooled down. Do not attempt to handle the parts of a hot oven.
- Take extreme care when handling the glass pane. Avoid the edges of the glass bumping against any surface. This may result in the glass shattering.
- Do not use harsh abrasive cleaners or sharp metal scrapers to clean the oven door glass since they can scratch the surface, which may result in shattering of the glass.
- If you notice any sign of damage on any of the glass panes (such as chipping, or cracks), do not use the oven. Call your Authorised Service Centre or Customer Care.
- Make sure you replace the glass pane correctly. Do not use the oven without glass pane correctly in place.
- If the glass pane feels difficult to remove or replace, do not force it. Call your Authorised Repairer or Customer Care for help.

Note: service visits providing assistance with using or maintaining the oven are not covered by your warranty.

REMOVING THE INNER PANE OF GLASS (only for the models with removable inner pane of glass)

The oven door is fitted with no. 2 panes:

- no. 1 outside;
- no. 1 inner.

To clean all panes on both sides it is necessary to remove the inner pane as follows:

1. Remove the oven door and place it on a soft surface.
IMPORTANT: The door shall be placed horizontally as per fig. 4.17.
2. Press down on both tabs to release the glass retainer.
3. Remove the glass retainer.
4. Lift and remove the inner pane slightly, as shown in the figure 4.18.

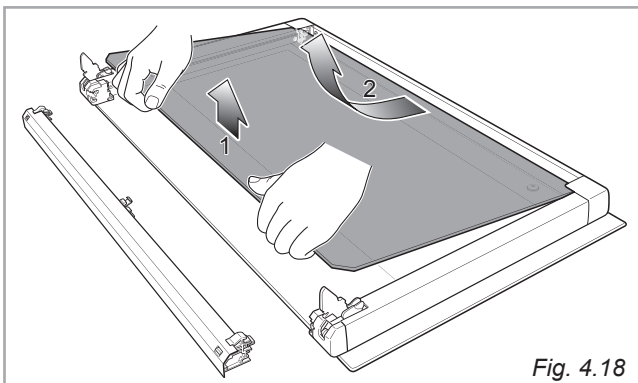
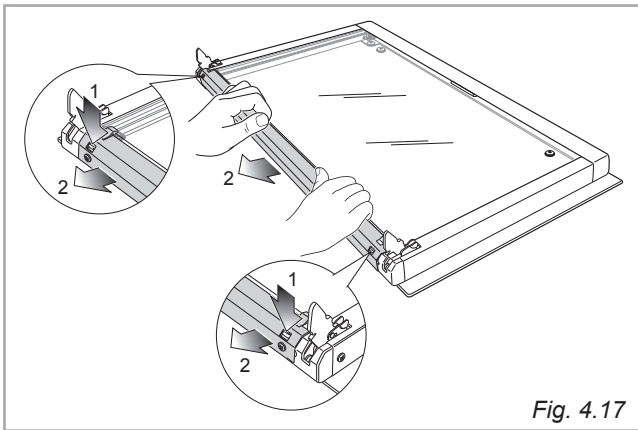

AFTER CLEANING, REPLACE THE INNER GLASS PANE (only for the models with removable inner pane of glass)

When replacing the inner glass pane, make sure that:

- You replace the pane correctly, as shown. The pane must be in the position described below in order to fit into the door and to ensure that the oven operates safely and correctly.
 - You take extra care not to bump the edges of the glass against any object or surface.
 - You do not force the pane into place. If you are experiencing difficulties replacing the pane, remove it and start the process again from the beginning. If this still does not help, call Customer Care.
 - Check that you are holding the pane the correct way. You should be able to read the wording on it as it faces you.
1. Insert the inner glass pane in the uppermost pair of grooves and push it slightly (arrow 1 in figure 4.19).
 2. Gently lower into place (arrow 2 in figure 4.19).

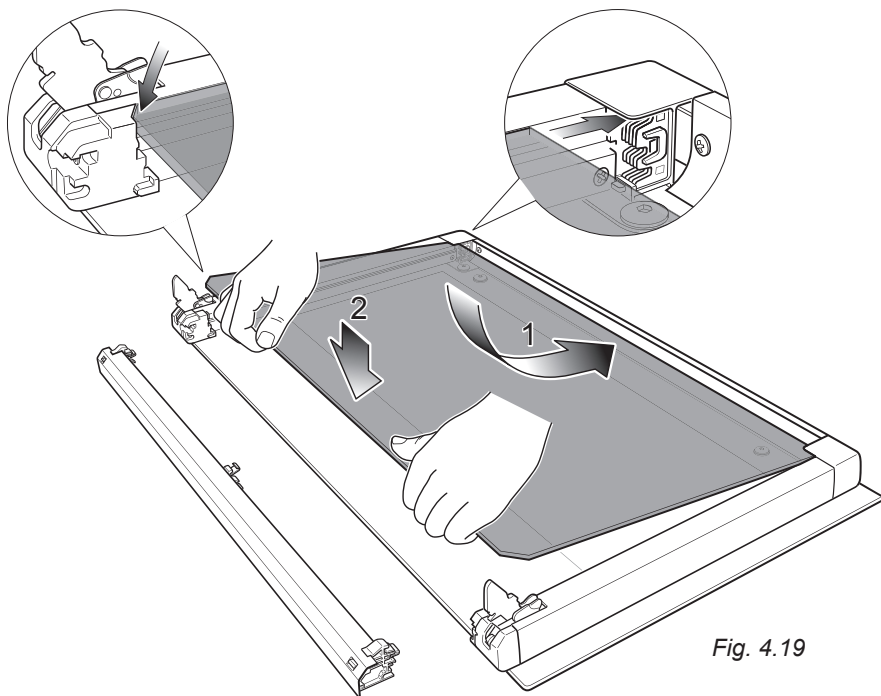

Fig. 4.19

REPLACE THE GLASS RETAINER (only for the models with removable inner pane of glass)

1. Position the glass retainer, as shown in the figure 4.20. It should sit on the bottom edge of the outer glass. Check that the clamps "M" are not deformed or damaged.
2. Gently push the glass retainer back into place. You should be able to hear the tabs on both sides click as they lock the glass retainer in.

Important !

Make sure the glass retainer is correctly and firmly in place and that the glass pane is secure.

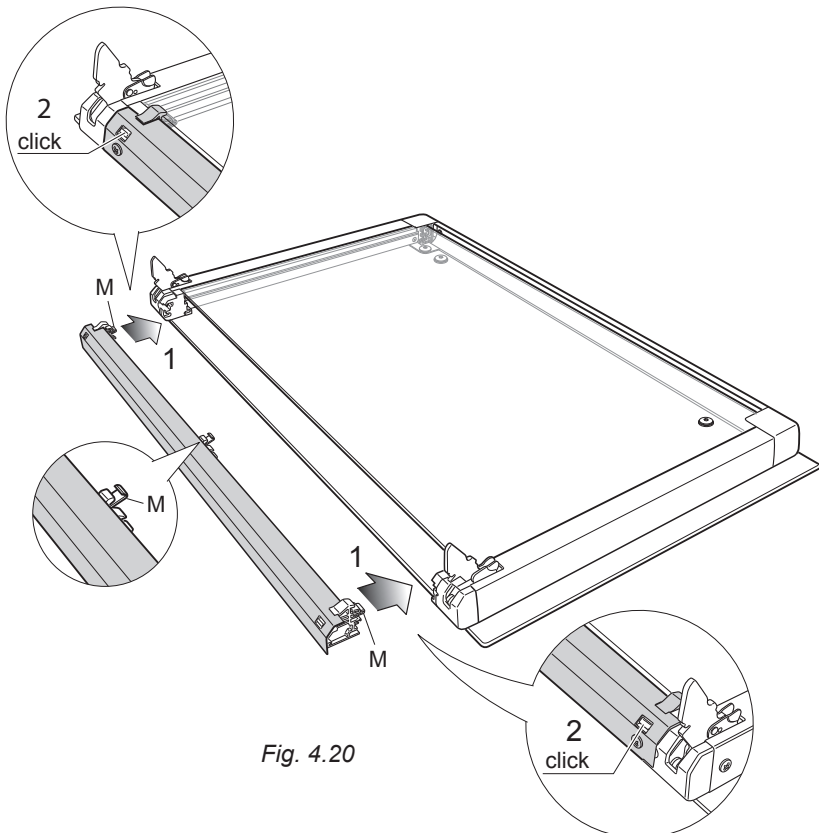

Fig. 4.20

DO'S AND DO NOT'S

- Do always grill with the oven door closed.
- Do read the user instructions carefully before using the oven for the first time.
- Do allow the oven to heat for about two hours, before using for the first time, in order to burn off any protective oils.
- Do clean your oven regularly.
- Do remove spills as soon as they occur.
- Do always use oven gloves when removing food shelves and trays from the oven.
- Do not allow children near the oven when in use.
- Do not allow fat or oils to build up in the oven trays, grill pan or oven base.
- Do not place cooking utensils or plates directly onto the oven base.
- Do not grill food containing fat without using the grid.
- Do not cover the grilling grid with aluminium-foil.
- Do not use the oven tray for roasting.
- Do not clean the oven without first turning off the electricity supply and allow to cool.
- Do not place hot enamel parts in water. Leave them to cool first.
- Do not allow vinegar, coffee, milk, saltwater, lemon or tomato juice to remain in contact with enamel parts.
- Do not use abrasive cleaners or powders that will scratch the surface of the enamel.
- Do not attempt to repair the internal workings of your oven.
- Do not line the oven walls with aluminium foil. Do not place baking trays or the drip tray on the base of the oven chamber.

FOR YOUR SAFETY

The product should only be used for its intended purpose which is for the cooking of domestic foodstuffs.

Under no circumstances should any external covers be removed for servicing or maintenance except by suitably qualified personnel.

ADVICE
for the
INSTALLER

5

INSTALLATION

IMPORTANT

- The installation must only be carried out by QUALIFIED TECHNICIANS. Failure to comply with this condition will render the guarantee invalid.
- The gas/electrical connection must be executed by a qualified technician in compliance with the regulations in force in your country and in observation of the manufacturer's instructions.
- Always disconnect the appliance from the electrical supply before carrying out any maintenance operations or repairs.
- Some appliances are supplied with a protective film on steel and aluminium parts. This film must be removed before using the appliance.
- The oven can be fitted in standard units, width 90 cm and depth 60 cm.
- Installation requires a compartment as illustrated in figures 5.1a and 5.1b.
- On the lower side, the oven must lay on supports standing the oven weight.
- **IMPORTANT: To ensure a proper ventilation of the appliance, an opening of at least 25 mm shall be made on the back of the surface supporting the oven (as shown in figure 5.2)**

The walls adjacent to the oven must be of material resistant to heat.

The walls of the unit must be capable of resisting temperatures of 75°C above room temperature.

Do not instal the appliance near inflammable materials (eg. curtains).

Caution: Do not lift this oven by the door handle

WARNING

When correctly installed, your product meets all safety requirements laid down for this type of product category.

However special care should be taken around the rear or the underneath of the appliance as these areas are not designed or intended to be touched and may contain sharp or rough edges, that may cause injury.

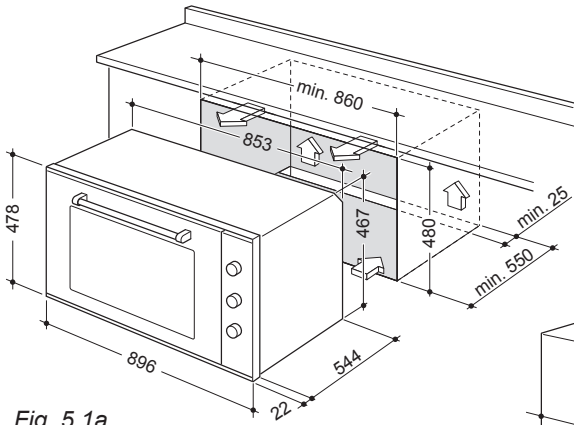

Fig. 5.1a

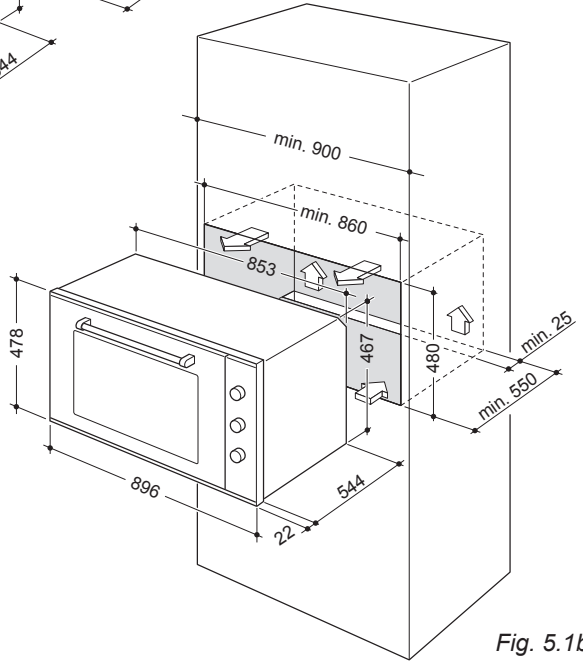

Fig. 5.1b

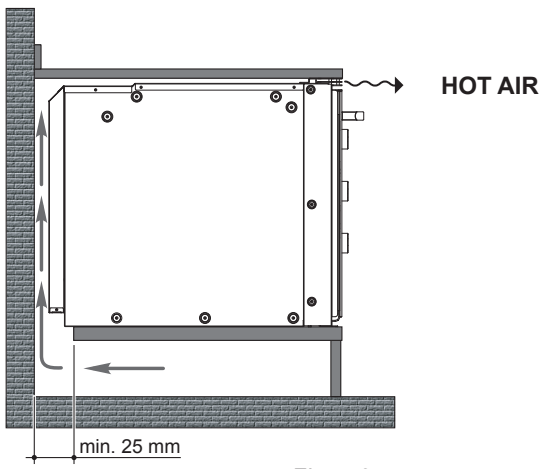
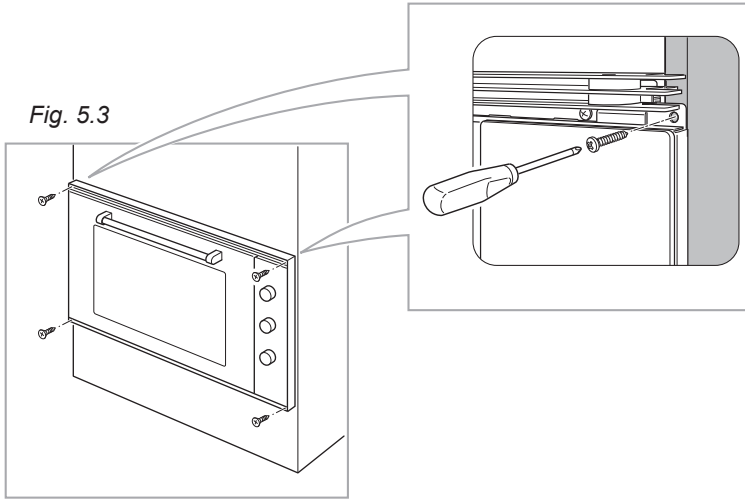

Fig. 5.2

FIXING THE OVEN

Introduce the oven into the furniture opening and fix it with 4 screws (not supplied) as figure 5.3. It is essential that the oven rests on a surface which will support its weight, as the screw fixing is only complementary.

Adjust the hinges of furniture doors adjacent to the oven to allow a 4-5 mm gap between the furniture door and the oven frame.



IMPORTANT:

To avoid damage to the lower trim please note the following instructions.

The lower trim is designed to allow for good air circulation and the correct opening of the oven door.

To ensure the trim is not damaged due to the appliance being placed on the floor, the appliance should be suitably supported as in illustration here below.

After installation the appliance door should be slowly opened to ensure no damage has occurred.

No responsibility for lower trim damage will be accepted if these instructions have not been followed.

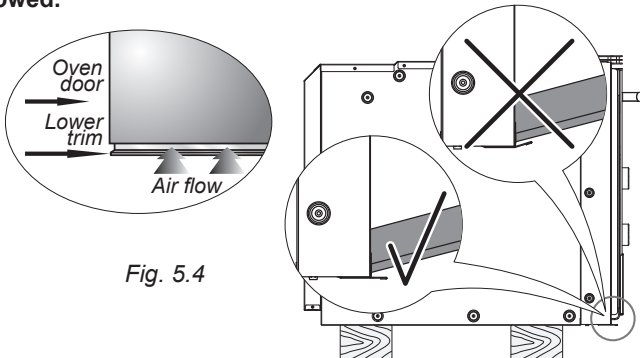

VENTILATION REQUIREMENTS (ALL COUNTRIES EXCEPT UK)

The appliance must be installed in compliance with applicable local regulations concerning ventilation and the evacuation of exhaust gases.

Intensive and prolonged use may require extra ventilation, e.g. opening a window, or more efficient ventilation increasing the mechanical suction power if this is fitted.

CHOOSING SUITABLE SURROUNDINGS

The room where the gas appliance is to be installed must have a natural flow of air so that the gas can burn (in compliance with applicable local regulations).

The flow of air must come directly from one or more openings made in the outside walls with a free area of at least 100 cm² (or refer to applicable local regulations).

The openings should be near the floor and preferably on the side opposite the exhaust for combustion products and must be made so that they cannot be blocked from either the inside or the outside.

When these openings cannot be made, the necessary air can come from an adjacent room which is ventilated as required, as long as it is not a bed room or a danger area (in compliance with applicable local regulations).

In this case, the kitchen door must allow the passage of the air.

DISCHARGING PRODUCTS OF COMBUSTION

Extractor hoods connected directly to the outside must be provided, to allow the products of combustion of the gas appliance to be discharged (fig. 5.5).

If this is not possible, an electric fan may be used, attached to the external wall or the window; the fan should have a capacity to circulate air at an hourly rate of 3-5 times the total volume of the kitchen (fig. 5.6).

The fan can only be installed if the room has suitable vents to allow air to enter, as described under the heading "Choosing suitable surroundings".

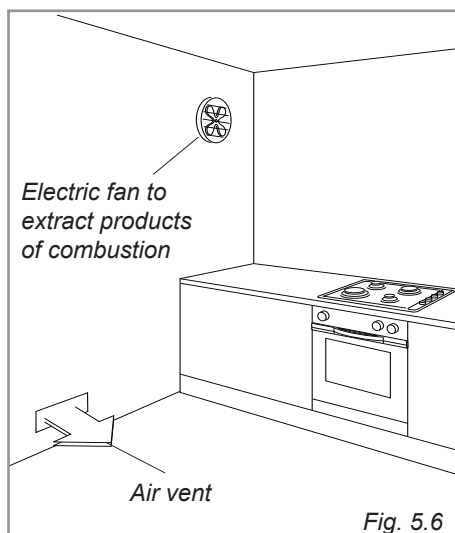
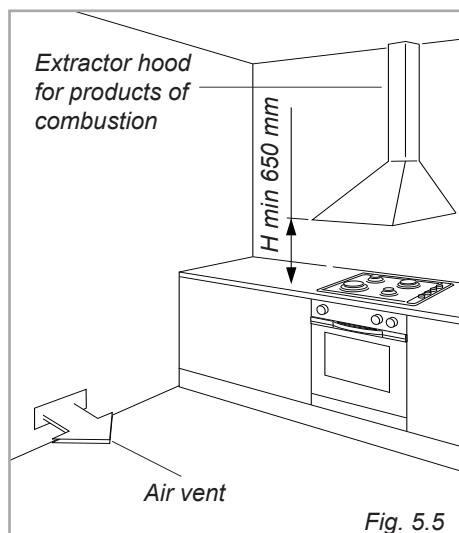

VENTILATION REQUIREMENTS (UNITED KINGDOM ONLY)

- The appliance should be installed in a room or space with an air supply in accordance with BS 5440:2 2000.
- For rooms with a volume of less than 5 m³, permanent ventilation through a free area of at least 100 cm² will be required.
- For rooms with a volume between 5 m³ and 10 m³, permanent ventilation through a free area of at least 50 cm² will be required, unless the room has a door which opens directly to the outside air, in which case no permanent ventilation is required.
- For rooms with a volume greater than 10 m³, no permanent ventilation is required.

Important !

Regardless of room size, all rooms containing the appliance must have direct access to the outside air via an openable window or equivalent.

- Where there are other fuel-burning appliances in the same room, BS 5440-2: 2000 should be consulted to determine the correct amount of free area ventilation requirements.
- The above requirements also allow for use of a gas oven and grill, but you need to consult a qualified engineer if there are other gas-burning appliances in the same room.

GAS INSTALLATION REQUIREMENTS

Important !

- **Before installation, make sure that the local distribution conditions (gas type and pressure) and the adjustment of this appliance are compatible. The appliance adjustment conditions are given on the plate or the label.**
- **This appliance must be installed and serviced only by a suitably qualified, registered installer with technical knowledge of both gas installation and electricity. The installation or service must comply with the current editions of the applicable standards, regulations, and codes of practice governing gas and electrical installations.**
- **Failure to install the appliance correctly could invalidate any manufacturer's warranty.**

This appliance is supplied for use on NATURAL GAS or LPG (check the gas regulation label attached on the appliance).

- Appliances supplied for use on NATURAL GAS: they are adjusted for this gas only and cannot be used on any other gas (LPG) without modification. The appliances are manufactured for conversion to LPG.
- Appliances supplied for use on LPG: they are adjusted for this gas only and cannot be used on any other gas (NATURAL GAS) without modification. The appliances are manufactured for conversion to NATURAL GAS.

If the NATURAL GAS/LPG conversion kit is not supplied with the appliance this kit can be purchased by contacting the After-Sales Service.

INSTALLATION & SERVICE REGULATIONS (UNITED KINGDOM ONLY)

This appliance must be installed and serviced only by a suitably qualified and registered person, and in accordance with the current editions of the following standards and regulations or other locally applicable regulations:

- Gas Safety (Installation & Use) Regulations
- Building Regulations
- British Standards
- Regulations for Electrical Installation

Installation and service of any gas product must be made by a suitably qualified person competent on the type of product being installed or serviced and holding a valid certificate of competence for the work being carried out. Currently the proof of competence is the Accredited Certification Scheme (ACS) or S/NVQ that has been aligned to the ACS.

It is also a requirement that all businesses or self employed installers are members of a class of person approved by the Health and Safety Executive.

Failure to install the appliance correctly could invalidate any manufacturers warranty and lead to prosecution under the above quoted regulation.

CONNECTING TO THE GAS SUPPLY

The gas connection fitting (figs. 5.2a - 5.2b) is made up of:

- the floating nut;
- the elbow;
- the gasket/s;
- the conical pipe fitting - to be used only if requested by the applicable local regulations (if the conical pipe fitting is not supplied with the appliance it can be purchased by contacting the After-Sales Service).
- conical adaptor with test point pressure - to be used for the United Kingdom only (if the conical adaptor is not supplied with the appliance it can be purchased by contacting the After-Sales Service).

The gas connection must be carried out by an authorised person according to the relevant local standards.

- If using a flexible hose, make sure it does not come into contact with moving parts.
- The rear panel is recessed to provide a channel for the appliance inlet pipe.
- The gas connection fitting can be turned in the direction required after loosening the elbow and floating nut connection.
- Never attempt to turn the elbow without having first loosened the floating nut.
- The supplied gaskets guarantee a good seal for the gas connection. We recommend that you replace the gaskets on the slightest sign of wear, deformation or imperfection.
- **After connecting to the gas mains, check that the couplings are correctly sealed, using soapy solution, but never a naked flame.**

FOR THE UNITED KINGDOM ONLY

Before connecting the appliance to the gas supply fit the conical adaptor with test point pressure (if not supplied with the appliance it can be purchased by contacting the After-Sales Service) to the elbow.

The installation of the gas appliance to Natural Gas or LP Gas must be carried out by a suitably qualified, registered installer.

Installers shall take due account of the provisions of the relevant British Standards Code of Practice, the Gas Safety Regulations and the Building Standards (Scotland) (Consolidation) Regulations issued by the Scottish Development Department.

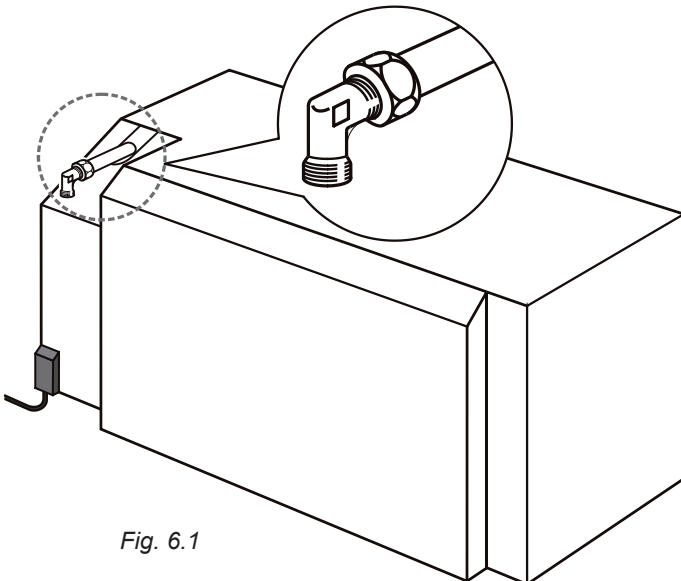

Fig. 6.1

DETAILS FOR CONNECTING TO THE GAS SUPPLY

The components described in the figs. 6.2a - 6.2b shall be fixed as indicated in the figs. 6.3a, 6.3b and 6.3c.

IMPORTANT: Firstly fix the components to the elbow, then connect the elbow to the appliance inlet pipe (figs 6.3a, 6.3b and 6.3c)

When using the conical adaptor with test point pressure (fig. 6.2b), the test point for measuring the gas pressure shall be oriented so that it is accessible.

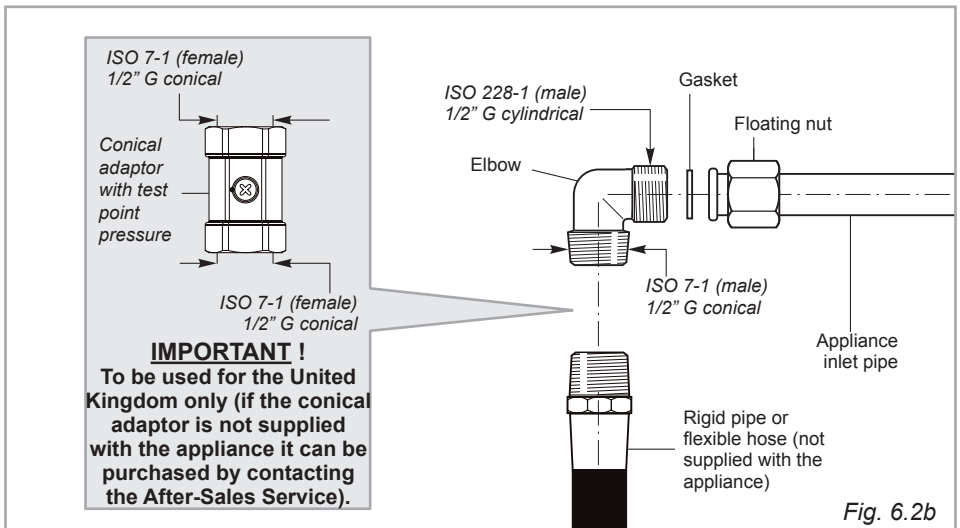
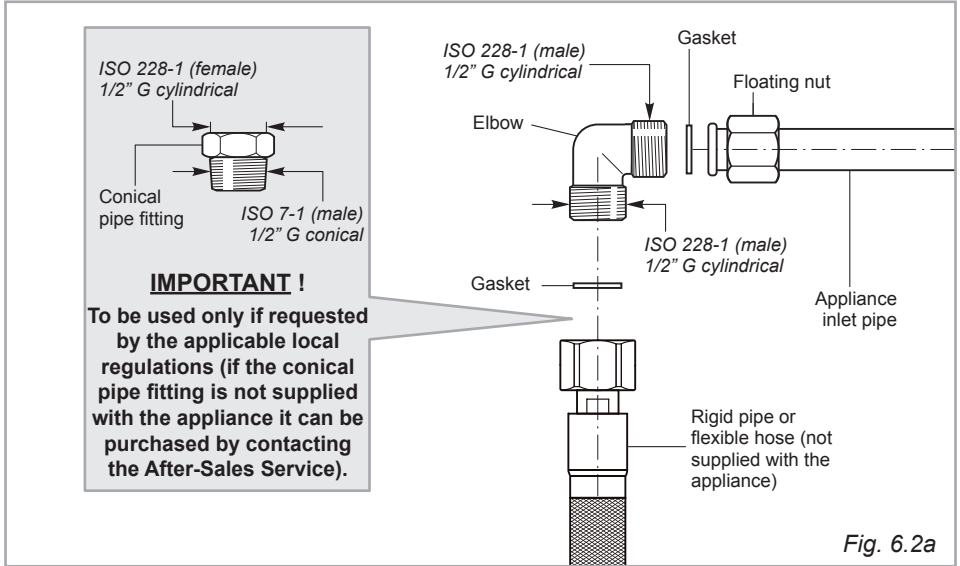

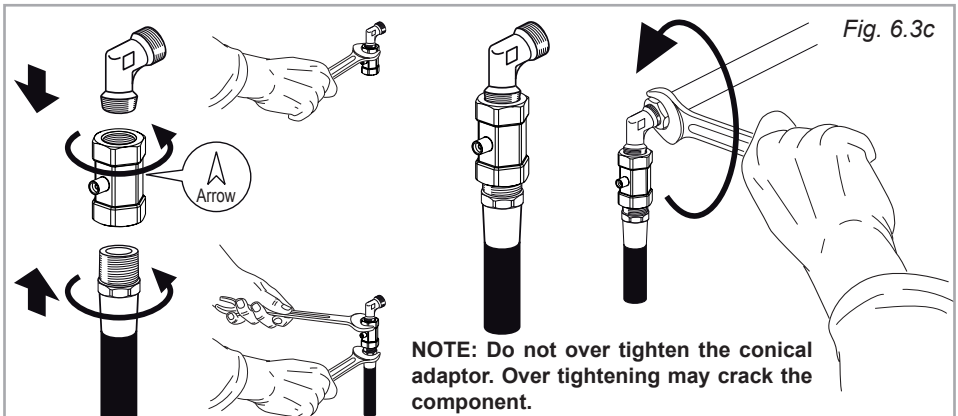
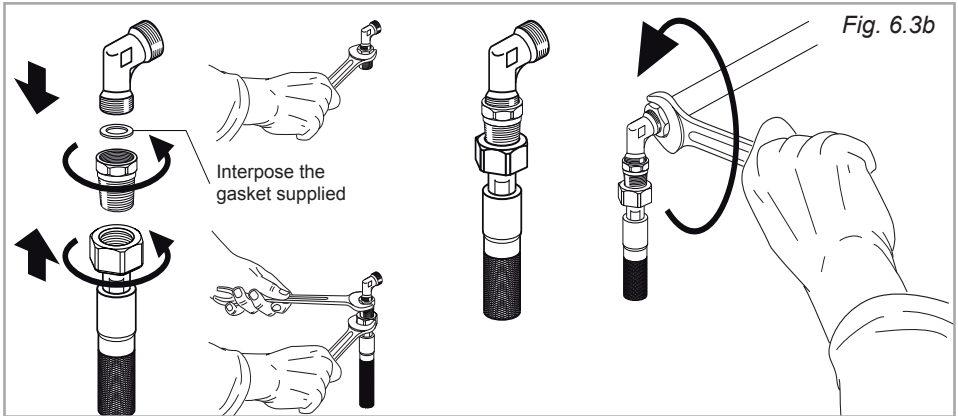
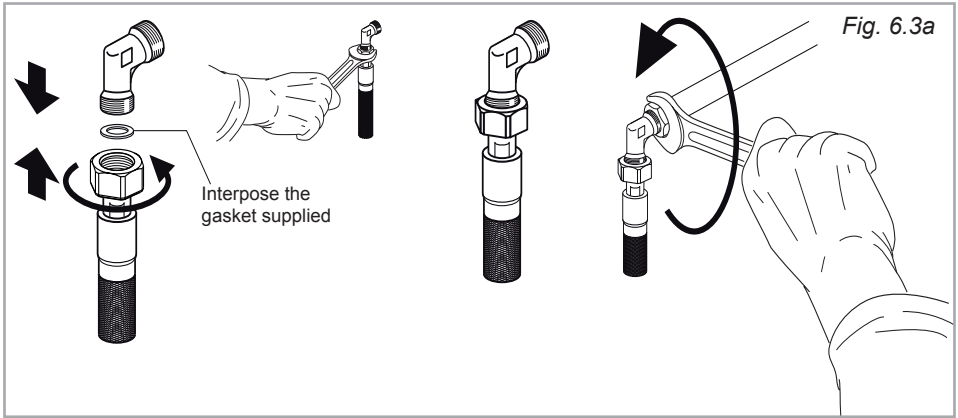

ADDITIONAL GAS CONNECTION REQUIREMENTS (UNITED KINGDOM ONLY)

It is recommended that the gas connection to the appliance is installed with a flexible connecting tube made to BS5386.

Flexible hoses can be used where the sited ambient temperature of the hose does not exceed 70°C.

These hoses must be manufactured in accordance with BS669 part 1 and be of the correct construction for the type of gas being used.

Gas hoses designed for natural gas **MUST NOT** be used for supplying LPG gas (LPG gas hoses can be identified by a either a red band or stripe on the rubber outer coating of the hose).

The hose should not be crushed or trapped or be in contact with sharp or abrasive edges.

ADDITIONAL GAS CONNECTION REQUIREMENTS (ALL COUNTRIES)

When connecting the appliance to the gas supply with rigid pipes or a flexible hose (which must comply with BS 669 in the UK), make sure that:

- You use rigid pipes or a flexible hose compliant with applicable local regulations. The flexible hose shall be of the correct construction for the type of gas being used and of the correct size to maintain the heat output of the appliance.
- The connection with rigid metal pipes does not cause stress or pressure to the gas piping.
- The flexible hose is not under tension, twisted, kinked, or too tightly bent, neither while the appliance is in use nor while it is being connected or disconnected.
- The flexible hose is not longer than 2000 mm (or refer to applicable local regulations) and does not come into contact with sharp edges, corners, or moving parts, as these may cause abrasion. Use a single flexible hose only; never connect the appliance with more than one flexible hose.
- The flexible hose can easily be inspected along its entire length to check its condition; if it has an expiry date, it should be replaced before that date.
- If using a flexible hose which is not entirely made of metal, make sure that it does not come into contact with any part of the appliance with a surface temperature of 70°C or above (or refer to applicable local regulations).
- The rigid pipe or flexible hose is replaced if it shows signs of damage.
- The flexible hose is not subject to excessive heat by direct exposure to flue products or by contact with hot surfaces.
- The socket into which the plug of the flexible hose fit is permanently attached to a firmly fixed gas installation pipe and is positioned so that the hose hangs freely downwards.
- The plug of the flexible hose is accessible after installation, so that it can be disconnected for service or removal.
- You inform the customer that the rigid pipe or flexible hose should not be subjected to corrosion by cleaning agents.

GAS MAINTENANCE

TABLE FOR THE CHOICE OF THE INJECTORS - Cat: II 2H 3+



BURNERS	Nominal power [kW]	Reduced power [kW]	LPG G30 (28-30 mbar) G31 (37 mbar)		Natural gas G20 (20 mbar)	
			Ø injector [1/100 mm]	Ring opening [mm]	Ø injector [1/100 mm]	Ring opening [mm]
Oven	4,00	1,10	96	Fully open (*)	142	4 (*)
Grill	2,50	-	78	2 (*)	115	2 (*)

(*) = Reference value

AIR VENT NECESSARY FOR GAS COMBUSTION = (2 m ³ /h x kW)	
BURNERS	Air necessary for combustion [m ³ /h]
Oven	8,00
Grill	5,00

LUBRICATION OF THE GAS TAPS

In case of difficulty in the gas taps operation, call Service.

IMPORTANT

All intervention regarding installation maintenance of the appliance must be fulfilled with original factory parts.

The manufacturer declines any liability resulting from the non-compliance of this obligation.

OPERATIONS TO BE EXECUTED FOR THE REPLACEMENT OF THE INJECTORS OF THE OVEN AND GRILL BURNERS

Some models are provided with a set of injectors for the various types of gas.

If the injectors are not supplied they can be obtained from the “Service Centre”.

Select the injectors to be replaced according to the “Table for the choice of the injectors”.

The nozzle diameters, expressed in hundredths of a millimetre, are marked on the body of each injector.

OVEN BURNER

- Lift and remove the lower panel inside the oven.
- Gently unlock, from the burner, the safety valve probe “V” and the ignition electrode “E” (as indicated in fig. 6.4a). Take care not to damage the probe and the ignition electrode.
- Unscrew and remove the burner securing screw “A” (fig. 6.4a).
- Withdraw the burner as shown in figure 6.4b.
- Using a 7 mm box spanner, unscrew the injector (indicated by the arrow in fig. 6.4b) and replace it with a new one selected in accordance with the “Table for the choice of the injectors”.
- Regulate the air supply to the oven burner as indicated in the section “REGULATION OF AIR SUPPLY TO OVEN AND GRILL BURNERS”; then replace the burner and the other components repeating the above steps in reverse order.

IMPORTANT: Pay special attention to replace correctly the safety valve probe “V” and the ignition electrode “E” as per figure 6.4a. Check the correct operation of the safety valve and the ignition electrode.

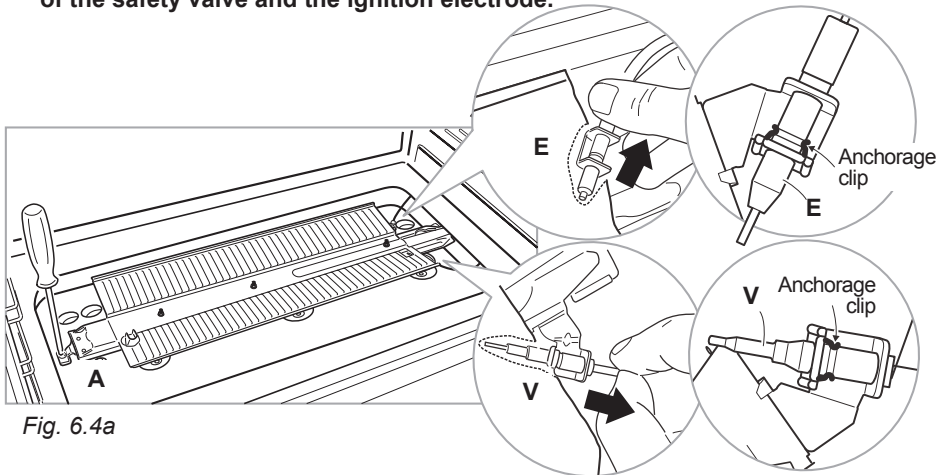

Fig. 6.4a

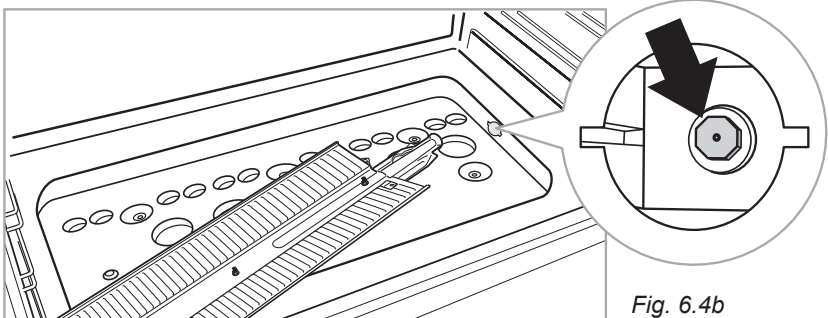
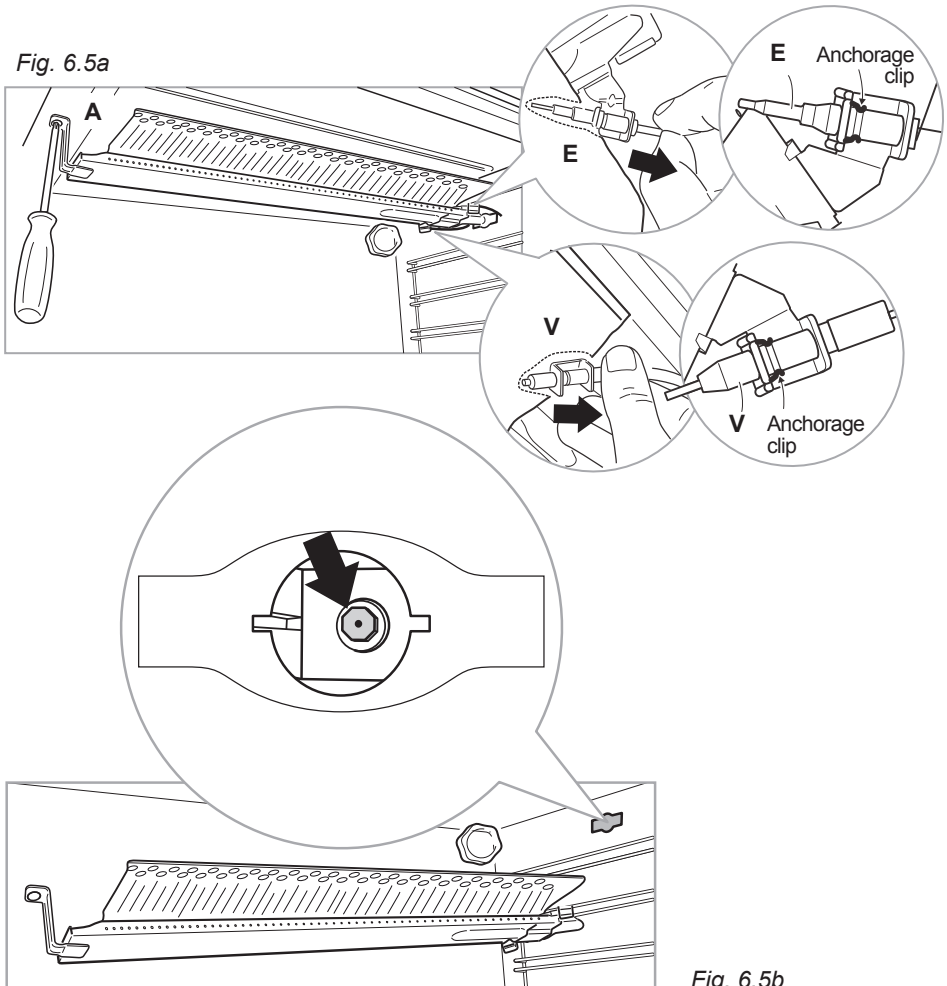

Fig. 6.4b

GRILL BURNER

- Gently unlock, from the burner, the safety valve probe “V” and the ignition electrode “E” (as indicated in fig. 6.5a). Take care not to damage the probe and the ignition electrode.
- Unscrew and remove the burner securing screw “A” (fig. 6.5a).
- Withdraw the burner as shown in figure 6.5b.
- Using a 7 mm box spanner, unscrew the injector (indicated by the arrow in fig. 6.5b) and replace it with a new one selected in accordance with the “Table for the choice of the injectors”.
- Regulate the air supply to the grill burner as indicated in the section “REGULATION OF AIR SUPPLY TO OVEN AND GRILL BURNERS”; then replace the burner and the other components repeating the above steps in reverse order.



IMPORTANT: Pay special attention to replace correctly the safety valve probe “V” and the ignition electrode “E” as per figure 6.5a. Check the correct operation of the safety valve and the ignition electrode.



REGULATION OF AIR SUPPLY TO OVEN AND GRILL BURNERS

To regulate the air supply it is necessary to remove the burners from the cavity (figs. 6.4b - 6.5b).

- Using a cross-head screwdriver, slacken the screws “B” securing the air flow regulation collar “A” (fig. 6.6) and move the collar forward or backward to increase or reduce the air aperture in accordance with gas type and the indications in the ‘Table for the choice of the injectors’.
- Light the burners and check the flames.

Flame faulty in primary air	Flame correct	Flame with excess primary air	
<i>flong, yellow and trembling</i>	<i>clear interior blue cone</i>	<i>short and sharp too blue interior cone tending to detach</i>	
CAUSE			
<i>air regulating tube, too closed</i>	<i>correct distance of the tube</i>	<i>air regulating tube, too open</i>	

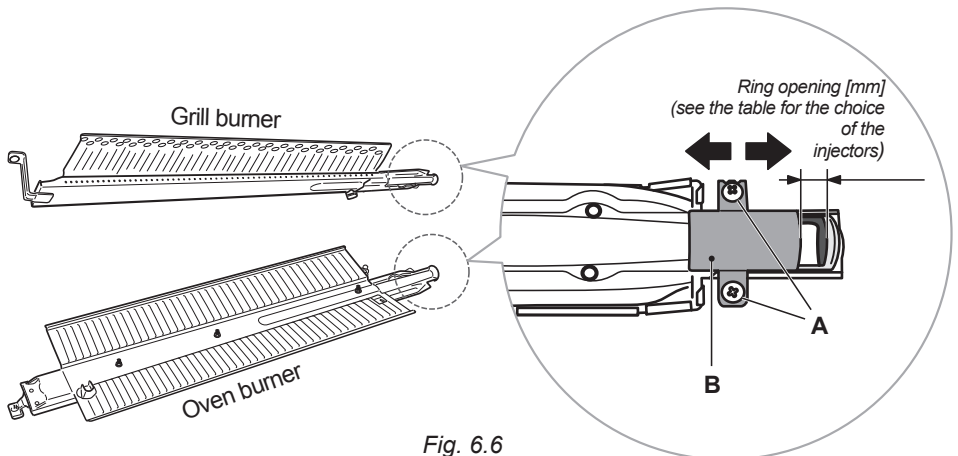

Fig. 6.6

ADJUSTMENT OF THE OVEN BURNER MINIMUM

This needs to be done only for the oven burner (the grill is a fixed capacity) by acting on the thermostat.

In the minimum position the flame must have a length of about 4 mm and must remain lit even with a brusque passage from the maximum position to that of minimum.

The flame adjustment is done in the following way:

- Turn on the oven burner by setting the thermostat knob on maximum position (“10” or “240”).
- Remove the knob and unscrew the by-pass screw “G” (fig. 6.7) about three times by passing a small flat screwdriver (Ø 3 mm blade, 100 mm length) through the control panel opening.
- Re-mount the knob and let the oven heat up for about 10 minutes, then bring the knob to the minimum position (“1” or “130”) to operate the thermostat by-pass.
- After having removed the knob again and being very careful not to turn the thermostat rod, slowly screw the by-pass screws “G” (fig. 6.7) until you obtain a flame of 3-4 mm in height.

N.B. For G30/G31 (LPG) the by-pass screw must be fixed thoroughly.

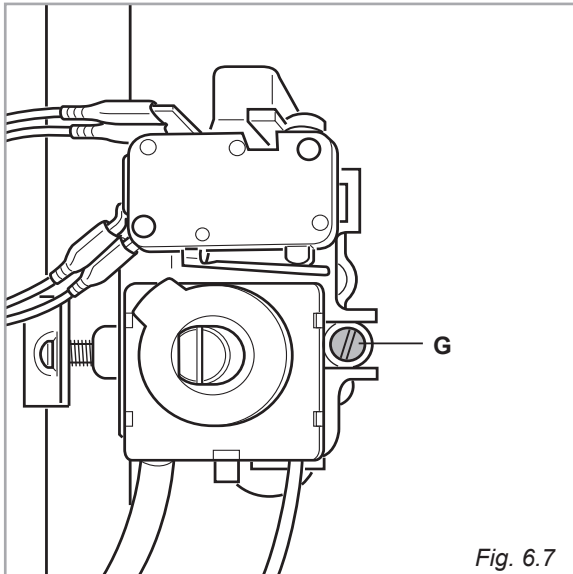

Fig. 6.7

Before effecting any intervention on the electrical parts the appliance must be disconnected from the network.

GENERAL

- The connection to the electrical network must be carried out by qualified personnel and must be according to existing norms.
- The appliance must be connected to the electrical network verifying above all that the voltage corresponds to the value indicated on the specifications plate and that the cables section of the electrical plant can bear the load which is also indicated on the plate.
- If the appliance is supplied without a power supply plug and if you are not connecting directly to the mains, a standardized plug suitable for the load must be fitted.
- The colours of the wires in the appliance power cable may not correspond with the colours marked on the terminals of your electrical plug/fuse spur outlet. For the connection proceed as follows:
 - The wire which is coloured green and yellow must be connected to the terminal which is marked with letter **E** or by the $\frac{\perp}{\equiv}$ (Earth) symbol or coloured green and yellow.
 - The wire which is coloured blue must be connected to the terminal which is marked with the letter **N** (Neutral) or coloured black.
 - The wire which is coloured brown must be connected to the terminal which is marked with letter **L** (Live) or coloured red.

- The bi-polar plug must be connected to an outlet connected to the grounding unit in conformity to security norms.
- If the oven is to be connected directly to the mains, it must be placed with an omnipolar switch with minimum opening between the contacts of 3 mm between the appliance and the mains.
- The power supply cable must not touch the hot parts and must be positioned so that it does not exceed 75°C at any point.
- Once the oven has been installed, the switch or socket must always be accessible.
- If the power supply cable is damaged it must be substituted by a suitable cable available in the after sales service.

N.B. For connection to the mains, do not use adapters, reducers or branching devices as they can cause overheating and burning.

If the installation requires alterations to the domestic electrical system call an expert. He should also check that the domestic electrical system is suitable for the power absorbed by the appliance.

The connection of the appliance to the grounding unit is mandatory. The manufacturer declines every responsibility for any inconvenience resulting from the inobservance of this condition.

**ADDITIONAL INSTRUCTIONS FOR THE UNITED KINGDOM ONLY
- MODELS SUPPLIED WITH A THREE PIN PLUG FITTED -**

A properly earthed three pin plug (fitted with a suitable fuse, BS1362 ASTA approved) must be used.

Note: Use a 3 A Fuse.

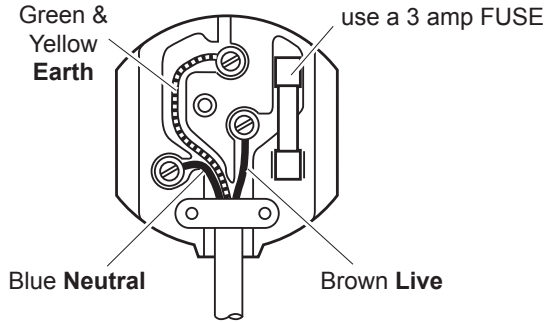

Fig. 7.1

**ADDITIONAL INSTRUCTIONS FOR THE UNITED KINGDOM ONLY
- MODELS SUPPLIED WITHOUT A POWER SUPPLY PLUG FITTED -**

MAINS ELECTRICITY CONNECTION

Incorrect installation may be dangerous and the manufacturer can not be held responsible.

THIS APPLIANCE MUST BE CONNECTED TO THE MAINS SUPPLY BY A COMPETENT PERSON, USING FIXED WIRING VIA A DOUBLE POLE SWITCHED FUSE SPUR OUTLET AND PROTECTED BY A 3A FUSE.

We recommend that the appliance is connected by a qualified electrician, who is a member of the N.I.C.E.I.C. and who will comply with the I.E.E. and local regulations.

Note: Use a 3A Fuse

Assembly and electrical connection should be carried out by specialised personnel.

When installing this product we recommend you seek the help of another individual.

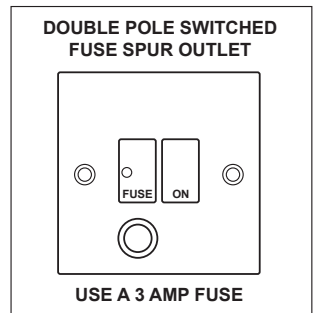

Fig. 7.2

FOR ALL THE COUNTRIES

CONNECTION OF THE POWER SUPPLY CABLE

- Unhook the terminal board cover by inserting a screwdriver into the two hooks “A” (fig. 7.3).
- Open the cable gland by unscrewing screw “F” (fig. 7.4), unscrew the terminal screws and remove the cable.
- The new supply cable, of suitable type and section, is connected to the terminal board following the diagram of fig. 7.5.

WARNING: If the power supply cable is damaged, it must be replaced only by an authorised service agent in order to avoid a hazard.

FEEDER CABLE SECTION TYPE “H05RR-F” or “H05V2V2-F”

220-240 V ac 3 x 0,75 mm²

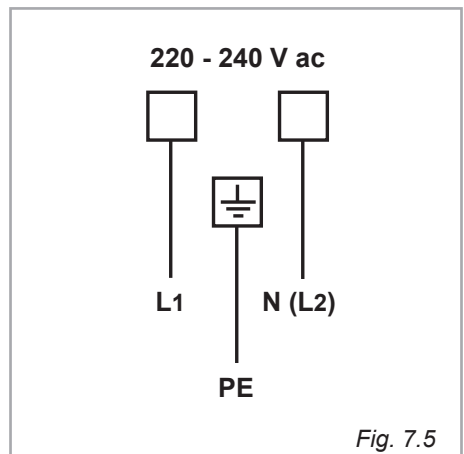
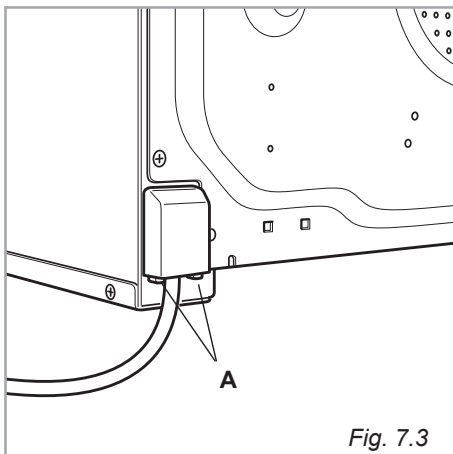
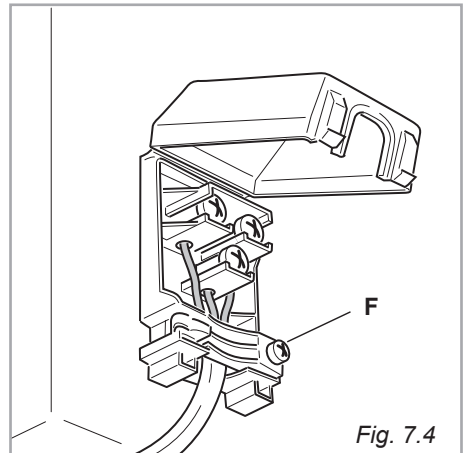

The manufacturer cannot be held responsible for possible inaccuracies due to printing or transcription errors in the present booklet.

The manufacturer reserves the right to make all modifications to its products deemed necessary for manufacturer commercial reasons at any moment and without prior notice, without jeopardising the essential functional and safety characteristics of the appliances.

www.elba-cookers.it

ELBA

TALENT FOR COOKING

 Made in Italy 

Cod. 1103791/GB - B5