

gorenje

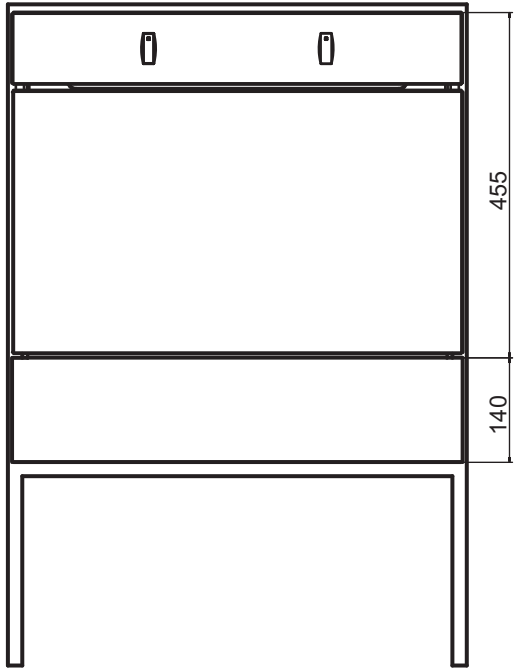

1.



2.

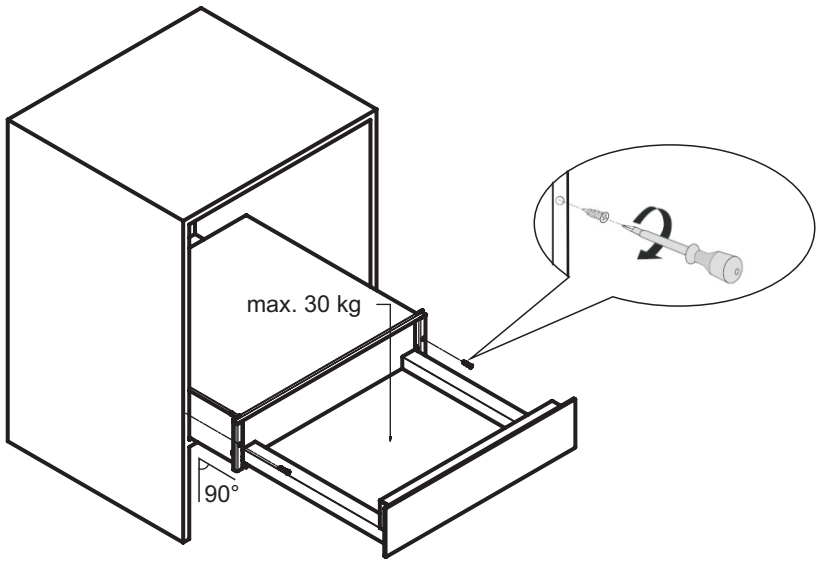

Dear customer,

You have purchased a product of our new series of appliances. We hope that our product will serve you well and for a long time.

Read this manual before installation and use of this appliance. It contains important information concerning how safely and economically operate the appliance. Save the manual together with the appliance for an eventual further use.

You can find this manual for use also on the web site:

www.gorenje.com / <<http://www.gorenje.com/>>



Important information



Tips, remarks

CONTENT

3	IMPORTANT INFORMATION, INSTRUCTIONS AND RECOMMENDATIONS	INTRODUCTION AND DESCRIPTION
6	DESCRIPTION AND OPERATION OF APPLIANCE	
9	THE USE OF WARMING DRAWER	OPERATION
12	DISPOSAL OF APPLIANCE AND PACKAGING	MAINTENANCE AND RECLAMATION
13	CLEANING AND MAINTENANCE	
14	CLAIMS	
15	THE CONNECTION OF APPLIANCE TO POWER NET	INSTALLATION
16	INSTRUCTIONS FOR INSTALLATION	
17	TROUBLESHOOTING	
18	TECHNICAL DATA	TECHNICAL DATA

IMPORTANT INFORMATION, INSTRUCTIONS AND RECOMMENDATIONS



SAFETY MEASURES

This appliance can be used by children aged from 8 years and above and persons with reduced physical, sensory or mental capabilities or lack of experience and knowledge if they have been given supervision or instruction concerning use of the appliance in a safe way and understand the hazards involved. Children shall not play with the appliance. Cleaning and user maintenance shall not be made by children without supervision.

Before connecting, check that the data concerning the nominal voltage on the product's data sheet corresponds with the voltage of your electrical network. The appliance should only be installed and connected to the electrical network by an authorized service technician or similarly qualified person with national standards and regulations.

The producer bears no responsibility for damage to the appliance or human health arising from faulty mounting or connecting.

Have the date of installation confirmed in the in the written Guarantee.

The producer bears no responsibility for damage to the appliance or from incorrect use or from defects in the protective systems of the electrical network (e.g. overvoltage).

Use the appliance after it has been fitted in the cabinet.

Caution! Never dismantle the cover of appliance. An eventual contact with alive parts means endangering of the user safety.

Caution! During any kind of dismantling or assembly of the appliance outside its normal use, the electrical supply to it should be disconnected and secured in the OFF state. When

disconnecting the appliance one of the following must be carried out:

- Switch off the fuse or circuit breaker in the distributor box.
- Pull out the plug from the socket. Do not pull the plug out by its cable but take hold of the plug itself.

Interference with the appliance or unprofessional service could lead to a risk of serious injury or damage to health as well as damage to the appliance itself. Installation and all repairs, modifications or checks to the appliance should be carried out by an authorized service technician or similarly qualified person only. The producer bears no responsibility for personal injuries or losses caused by incorrect manipulation or unprofessional interference with the appliance.

A damaged feed cable must only be replaced by a service technician or other professionally competent person to prevent dangerous situations arising.

If any fault occurs in the appliance within the guarantee period, do not repair it yourself. Put the appliance out of service and request repair from an authorized person competent for such work. The producer is not responsible for eventual losses arising from failure to observe the instructions and recommendations given in this manual.

This appliance is intended solely for domestic use!

Incorrect use could endanger the user.

This appliance should only be used for warming dinner service, keeping food warm, for preparation of yogurt, and similar uses. Any other use is not acceptable and could be dangerous. The producer accepts no responsibility for dropouts or defects arising as a consequence of unsuitable or incorrect use of the appliance.

Depending on the chosen temperature and duration of operation, the temperature inside the appliance can reach up to 80 °C. Use

oven gloves or a teatowel to remove dishes from the warming drawer.

WARNING: The appliance self and its accessible parts will be hot during the use.

Children under the age of 8 should not be allowed near the appliance except under adult supervision.

Do not sit or lean on the drawer. This could damage the telescopic fittings.

Maximum load of drawer is 30 kg.

CAUTION! Danger of fire: Do not put synthetic dishes or flammable objects into the warming drawer. Such dishes or objects could melt or ignite after the drawer is switched on.

Do not use for other purposes, for instance for room heating. The high temperatures could cause the ignition of flammable objects near the appliance.

Never use steam or pressure cleaners for cleaning of the appliance.

There is a risk of electric shock. The steam could damage the electrical parts and cause a short circuit. The steam pressure could permanently damage the surface and parts of the appliance.

When you stop using the appliance, such as at the end of its operational life, disconnect it from the mains and remove the feed cable to ensure the safe state of appliance.

THE PURPOSE OF THE APPLIANCE

The appliance is designed for usual preparation of food in households and it should not be used for other purposes.

The individual possibilities of its use are fully described in this manual.

DESCRIPTION AND OPERATION OF APPLIANCE

This appliance is intended for fitting into kitchen units and is designed for warming dinner service, defrosting food, keeping food warm and for preparation of yogurts.

Warming is carried out by a convection system which pumps warm air into the drawer. Thanks to circulation of the air dishes are heated up evenly and quickly. Even so, dishes in the rear part of the drawer could be hotter than those at the front.

The control panel includes control sensors with pre-defined programs as well as a manual mode, which offers a selection temperatures from 40–80 °C (in 10°C steps) and automatic switching off at the end of the set warming period (1–4 hours).

The appliance will heat correctly only if the drawer is properly closed.

CONTROL ELEMENTS

The sensor control is activated by touching the corresponding symbol on the control panel with your finger. The control panel should therefore be kept clean and dry.

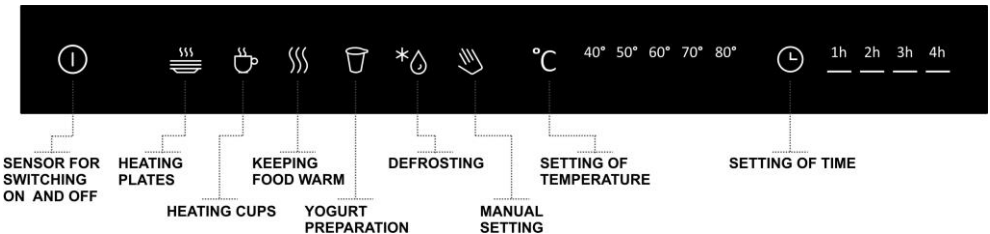

Sensor for switching on and off

- Heating plates
- Heating cups
- Keeping food warm
- Yogurt preparation
- Defrosting

Automatic programs

- Manual setting
- Setting of temperature
- Setting of time

Manual operation

Before first use

Clean the appliance according to the instructions in the chapter „Cleaning and maintenance“ before first use.

Then leave the warming drawer in operation at maximum temperature for at least two hours. Ensure good ventilation of kitchen during this procedure. The parts of this appliance are protected with a special coating which can be smelt during this first heating. This smell and any smoke will disappear after a short period. It does not mean that the appliance or its connection are in any way defective.

Capacity

The capacity can differ with the size of dishes used.

Orientation capacity guide

Serving set for 6 persons

6 dinner plates	25.5 cm diam.
6 soup plates	22 cm diam.
6 dessert plates	23.5 cm diam.
1 oval plate	width 32 cm
1 serving plate	19.5 cm diam.
1 serving plate	18.5 cm diam.

Maximum load of drawer is 30 kg.

THE USE OF WARMING DRAWER

- 1 - Open the drawer...
- 2 - Switch ON the drawer by pressing on the touch sensor on/off.
- 3 - Place the dishes into the drawer.
- 4 - Select a suitable program or choose the manual operation and set the temperature and time.
- 5 - Close the drawer...

At the end of the heating time the heating system will stop and a signal will sound. The signal will sound continuously for one minute and then a short signal will sound after every minute. The drawer switches off five minutes after the selected program finishes.

If you want to interrupt the selected program open the drawer and press the touch sensor for switching it off. You can then select another program or prolong the heating duration after opening of the drawer.

Remark

When interrupting an automatic program the warming drawer will switch to manual operation. The change can not be done in the program Yogurt.

Heating time

Different factors can influence the length of the heating time:

- The material and thickness of dishes
- The quantity of heated dishes
- The method of organization in the drawer
- The setting of temperature

Perfect warming-through can therefore last different periods of time. The pre-set programs are in this regard for orientation only. After a while you will get to know what is the ideal heating time for your particular dishes.

The dishes in the rear part of the drawer could be hotter as in the front part of the drawer. Use oven gloves or a kitchen cloth for removing dishes from the drawer.

THE USE OF WARMING DRAWER

The switching the drawer on

The drawer can be switched on by pressing the ON touch sensor.



AUTOMATIC PROGRAMS

Heating plates

Select the program for Heating plates.



This automatic program has a pre-set **temperature of 80 °C** and a **1 hour** heating time. **It is designed for pre-heating of dinner servings.** The pre-heated plates preserve the temperature of the served food.

Heating cups

Select the program for Heating cups.



This automatic program has a pre-set **temperature of 60 °C** and a **1 hour** heating time. **It is designed for pre-heating** cups for preparation of warm drinks such as espresso coffee.

Keeping food warm

Select the program for Keeping food warm.



This automatic program has a pre-set **temperature of 60 °C** and a **2 hour** heating time. **It is designed for keeping** cooked food warm in the dish or on serving plates.

Yogurt

Select the program for Yogurt preparation.



This automatic program has a pre-set **temperature of 40 °C** and a **4 hour** heating time. **It is designed for yogurt preparation.** This procedure requires an exact temperature setting and an exactly determined duration, therefore these values cannot be modified.

Tip: Yogurt preparation

Heat up 1 liter of fresh full-cream milk to a temperature approximately 80 °C and then let it cool down to 40 °C. Stir into the milk 2 spoons of white yogurt with living culture. Pour the milk into jars. The jars should be totally clean, ideally sterilized. Put the jars into the center of the drawer. Don't put the jars closer than 10 cm from the back wall of the drawer. The air has to circulate around the jars, leave the gaps between them. Select the program for Yogurt. The program is complete after 4 hours, then let the yogurt an additional 2 hours in the drawer without heating. The yogurt will be ready after 10 hours in the refrigerator where it needs to ripe.

Defrosting

Select the program for Defrosting.



This automatic program has a pre-set **temperature of 40 °C** and a **2 hour** heating time. **It is designed for defrosting** frozen food. Put the frozen food into a deeper dish or plate to catch water released during thawing.

MANUAL OPERATION

Select the Manual operation touch sensor.



Select the required temperature by repeatedly pressing the temperature touch sensor.



A selection of temperatures between 40–80 °C are offered in 10 °C steps. The selected temperature is shown on the temperature display.



Select the required heating time period.



A selection of heating times from 1–4 hours is offered in 1 hour steps. The selected time period is shown on the time display.

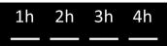

Child lock

The child lock is used to prevent children interfering with the drawer controls. You can activate the child lock by pressing the "Manual operation" touch sensor for 5 seconds.



The sensors will then be inactive. Only the "Manual operation" symbol will be lit up. The child lock can be deactivated by again pressing the "Manual operation" touch sensor for 5 seconds.

Switching the drawer off

You can switch the drawer off by pressing the OFF touch sensor.



The drawer switches off automatically at the end of the set heating time.

DISPOSAL OF APPLIANCE AND PACKAGING



The symbol on the product or on its packaging determines that this appliance should not be given into the domestic waste. It should be delivered to a collection spot for recycling of electric and electronic appliances. You can help to prevent the negative influences on the environment and human health (which could be caused with inappropriate disposal) with correct disposal of this appliance. More detailed information on recycling of this product you can receive at competent local authority, service for disposal of domestic waste or in the shop, where you had bought the product.

The packaging materials protect the appliance during transport. By recycling the packaging it is possible to save raw materials and reduce waste volumes.

If you dispose of the packaging yourself, ask local authorities for the location of the nearest collection centre.

CLEANING AND MAINTENANCE

Warning

Never use steam cleaners or high pressure cleaners for cleaning of the appliance.

For removing of inner glass bottom use enclosed vacuum handle. See picture n.4.

Clean all surfaces with a soft sponge, a drop of detergent and lukewarm water. Then dry all surfaces with a soft cloth.

Clean front glass panel with cleaning means for glass and soft cloth. Do not use scraper.

Do not use: Detergents containing soda, acids or chloride, abrasive detergents (powder or cream) abrasive sponges (e.g. steel wool pads) or sponges containing residual abrasive detergent.

CLAIMS

If there is any defect on the appliance within the guarantee period, do not repair it self. Apply a claim in the shop in which you bought the appliance or at service representatives, mentioned in the Guarantee conditions. At applying of claim observe the text of Guarantee sheet and Guarantee conditions. The claim is valid with submitted dully filled up Guarantee sheet only.

THE CONNECTION OF APPLIANCE TO THE POWER MAINS

The appliance may only be connected to the electrical network by an authorized person and in compliance with national standards and regulations. A device for disconnecting all poles of the appliance should be included in the circuit before the appliance for disconnecting the appliance from the network. This obligation is not necessary, when the supply cord is provided with a plug and this plug can be easily and without obstruction pulled out from the socket.

The appliance is delivered with a 1.5 mm diameter, three-core cable, type H05VV-F 3G1,5. The wire ends should be fastened against fraying with pressed on cable ends.

The appliance must be connected to a mains supply with the correct voltage as indicated on the rating plate and by means of a supply line of the appropriate rating.

CONNECTION

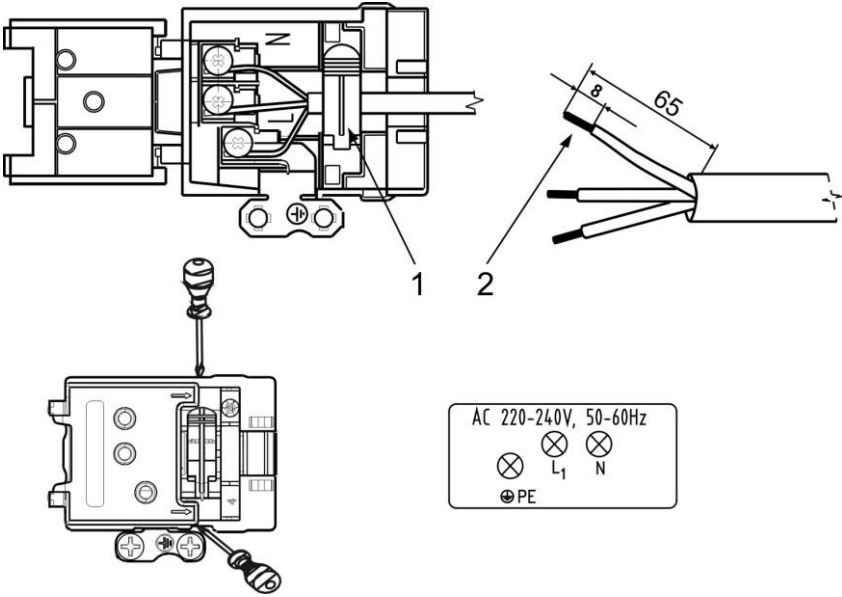

1. Clip against cord tearing
2. Wire ends braced with pressed terminal

INSTRUCTIONS FOR INSTALLATION

At installation of appliance the following steps should be provided from point of view of appliance:

The checking of correct connection to electric power net.

Checking the functioning of the heating element, ventilator and regulation elements.

The demonstration of appliance's all functions, operation and maintenance to the customer.

IMPORTANT NOTE!

At any manipulation with the appliance, except of normal use, it is necessary to disconnect the power, e.g. with pulling out of the plug from the socket or with switching off the main switch in front of the appliance.



This appliance is not designed for operation with help of an external timer or with a separate system of remote control.

TROUBLESHOOTING

CAUTION! All repairs should only be carried out by a service technician or similarly qualified person. Repairs carried out by persons not authorized by the producer could be dangerous.

In case of minor defects first check if you can correct the fault with the help of this manual.

The dishes are not sufficiently heated.

Check, whether:

- the appliance is switched on;
- a suitable temperature has been set;
- the back wall of the drawer is not fully covered with the dishes;
- the dishes were heated long enough.

The time for heating depends on different factors including:

- the material and thickness of dishes;
- the quantity of dishes;
- the arrangement of dishes,

The dishes are not heated at all.

Check, whether:

- the fuse hasn't blown or the circuit breaker in the distributor box hasn't been tripped.
- you can hear the ventilator working.

If the ventilator is running then the heating element is defective.

A faulty temperature sensor is signaled by a flashing temperature display and intermittent sound signal. The drawer will then automatically switch off.

TECHNICAL DATA

Technical data		
WARMING DRAWER	WD1410X WD1410B	WD1410WG WD1410BG
Dimensions	560 x 595 x 140 mm	
Electric voltage	220-230 V ~; 50/60 Hz	
Total electric input	405 W	

SAP 542554

MORA MORAVIA, s.r.o., Hlubočky–Mariánské Údolí, Czech Republic



The producer reserves the right for small modifications of manual, following from the technical or technological changes of product, which have no influence to the function of product

